

Electric Vehicle Charging Infrastructure in Shared Parking Areas:

Resources to Support
Implementation & Charging
Infrastructure Requirements



This report was prepared with generous support of the BC Hydro Sustainable Communities program. The City of Richmond managed its development and publication.

The City of Richmond would like to acknowledge and express their appreciation to the following people who provided helpful comments on early drafts of material developed as part of this project:

- Katherine King and Cheong Siew, BC Hydro
- Jeff Fisher, Dana Westermarck and Jonathan Meads, on behalf of the Urban Development Institute
- Ian Neville, City of Vancouver
- Lise Townsend, City of Burnaby
- Neil MacEachern, City of Port Coquitlam
- Maggie Baynham, District of Saanich
- Nikki Elliot, Capital Regional District
- Chris Frye, BC Ministry of Energy Mines and Petroleum Resources
- John Roston, Plug-in Richmond

Responsibility for the content of this report lies with the authors, and not the individuals nor organizations noted above.

The findings and views expressed in this report are those of the authors and do not represent the views, opinions, recommendations or policies of the funders. Nothing in this publication is an endorsement of any particular product or proprietary building system.

Authored by:
AES Engineering
Hamilton & Company
C2MP
Fraser Basin Council



**HAMILTON
& COMPANY**
— STRATA | LITIGATION —



Fraser Basin Council

Report submitted by:
AES Engineering
1330 Granville Street
Vancouver, BC

TABLE OF CONTENTS

1.0 SCOPE	1
1.1 General.....	1
2.0 CONFIGURATIONS	2
2.1 General.....	2
2.2 Dedicated Circuit	2
2.3 Circuit Sharing	3
Static Load Management.....	3
Rotational (Time-Shared) Load Management.....	3
Dynamic Load Management.....	4
2.4 Panel Load Management.....	5
2.5 Dwelling Demand Load Management	6
2.6 Building Demand Load Management	7
3.0 COMPARISONS	8
3.1 General.....	8
3.2 Mounting Option	8
3.3 Charging Ports.....	8
3.4 Circuit Rating and Output Ampacity	8
3.5 Cost	8
3.6 Certification.....	8
3.7 Questionnaire	8
3.8 Potential Solutions	9
4.0 DELIVERY MODELS	10
4.1 General.....	10
5.0 VARIANCE PROCESS	11
5.1 General.....	11
6.0 KEY CONSIDERATIONS FOR STRATA BYLAWS AND/OR RULES	13
6.1 General.....	13
6.2 List of Issues.....	13

APPENDIX A: CONFIGURATIONS

APPENDIX B: COMPARISON TABLES

APPENDIX C: LOAD MANAGEMENT (EVEMS) QUESTIONNAIRE

APPENDIX D: CODE AMENDMENTS

APPENDIX E: VARIANCE FORMS

APPENDIX F: STRATA ISSUES

1.0 SCOPE

1.1 General

The City of Richmond's Official Community Plan (OCP) includes a target to reduce Richmond's community greenhouse gas emissions 80% below 2007 levels by 2050. Richmond's Community Energy and Emissions Plan (CEEP) identifies that to reach this target will require near universal adoption of zero carbon vehicles by the 2040s. The CEEP includes Strategy 7 to "Promote Low Carbon Vehicles", and actions pursuant to this strategy.

In accordance with this CEEP action, the City of Richmond recently adopted amendments to the Parking and Loading section of the Richmond Zoning Bylaw, establishing requirements for provision of electric vehicle (EV) charging infrastructure in new developments. Amendments require all residential parking, excluding visitor parking, feature an energized outlet capable of delivering Level 2 EV charging (as defined by *SAE J1772* standard – i.e. 208V/240V). Intention of the requirement is to better future-proof buildings so that at-home charging is readily accessible.

To assist implementation of the requirements, the City aims to issue technical bulletins that 1) describe suitable electrical configurations, and 2) provide guidance on expectations for strata rules/bylaws that owner-developers can provide for future strata organizations to facilitate successful operation of EV charging infrastructure.

Other municipalities in the Province of British Columbia are similarly considering options to encourage adoption of EVs, to support climate, air-quality, economic development and livability goals. A number of municipalities have already revised policies pertaining to EV charging, and others are in the process. Pursuant to such efforts, the objective of the following report is to:

Provide resources to support implementation of EV charging infrastructure in shared parking areas.

To achieve the objective, the intent is to provide City of Richmond, other municipalities, developers, electrical designers, and end-users an understanding of available electric vehicle supply equipment (EVSE) solutions and identify inherent implications. Major components include:

1. Infrastructure configurations and comparisons;
2. Delivery models;
3. Variance request requirements;
4. User fee assignment and electricity cost reconciliation assessment;
5. Model strata rules/bylaws development;
6. Local government guide development.

Refer to the following sections for details of configuration and delivery model descriptions and comparisons.

2.0 CONFIGURATIONS

2.1 General

EVSE configurations include:

- dedicated circuits;
- circuit sharing:
 - static load management;
 - rotational (time-shared) load management;
 - dynamic load management;
- panel load management;
- dwelling panel load management;
- building demand load management.

Refer to the following subsections and configuration table (*Appendix A*) for further details.

2.2 Dedicated Circuit

Definition: An EVSE supplied from a dedicated branch circuit.

Dedicated circuits require significant electrical system infrastructure to accommodate the electrical load and dedicated wiring to each stall. A demand factor of 100% is required, as per CSA C22.1-15. Allowance for diversity is permitted in Table 38 of CSA C22.1-18 (*Appendix D*), when adopted (anticipated early 2019).

The configuration is versatile, as it is possible to provide 6-50R or 14-50R receptacles during building construction to allow users to purchase and install a standalone EVSE of their choice. Performance is typically higher than other configurations, as there is no impact from other EVSE. Refer to the following diagram for general arrangement.

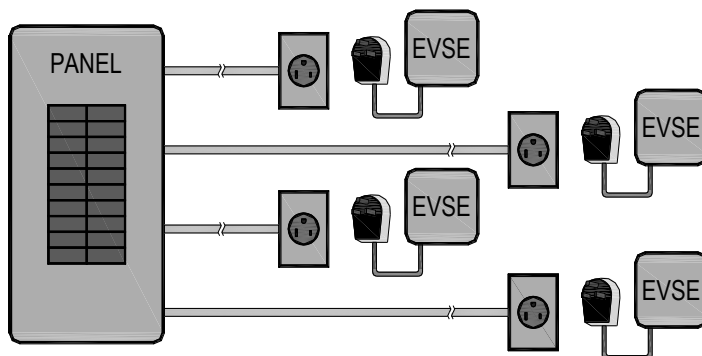

Figure 1: Dedicated Circuit

2.3 Circuit Sharing

Definition: Multiple EVSE supplied from a single branch circuit, with demand controlled to ensure circuit rating is not exceeded.

Circuit sharing is the connection of multiple EVSE to a single branch circuit. This configuration depends on the ability to monitor the consumption of the EV to dynamically reallocate power. A demand factor of 100% is required, as per CSA C22.1-15. Allowance for diversity is permitted in accordance with Rule 8-106(10) (*Appendix D*) of CSA C22.1-18, when adopted. Reduction in electrical system infrastructure is achievable, dependent on the number of EVSE per circuit.

The following subsections provide overview of various circuit sharing configurations.

Static Load Management

Definition: Control of charging based on equal power allocation to each EVSE.

Static load management is typically selected for small scale installations due to reduced installation costs, design simplicity, ease of system setup, and avoidance of service fees. Static Load management apportions, typically equally, the available charging capacity, between the EVSE connected to a branch circuit. For a simple arrangement with two EVSE on one circuit, when one EVSE is charging, it receives 100% of the available capacity, and when two are charging each EVSE receives 50% of the available capacity. The chargers do not have the ability to dynamically change the power apportioning between EVSE based on the demand of the specific EV. Additional hardware is typically not required when load management capability is integral to the EVSE.

The disadvantage is significant reduction in utilization of available power, in the majority of scenarios, compared to dynamic load management. Refer to the following diagram for general arrangement.

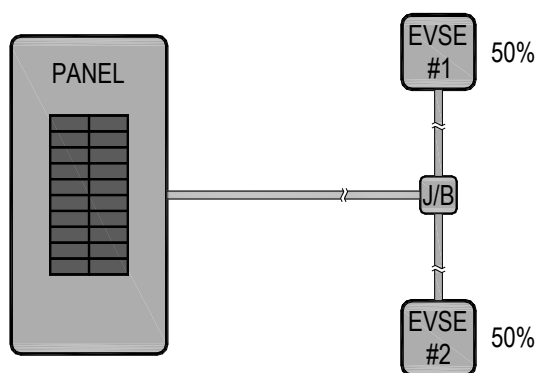

Figure 2: Static Circuit Sharing

Rotational (Time-Shared) Load Management

Definition: Control of charging based on time allocation.

Rotational load management typically includes a system controller that allocates charging in accordance with a predetermined schedule and duration. Charging is provided to one EVSE for a specified period and then charging is provided to next in the sequence. Controllers typically operate independently, and without communication with the EVSE.

The configuration is only recommended for long-term parking scenarios and/or interchangeable assignment corporate fleets. Disadvantages of the arrangement are the inability to identify specific charging time of a particular vehicle, concerns associated with switching input power to EVSE, random delay of charging of EVSE upon power return, inefficiencies when a vehicle is not connected, and inability to identify a defective charger. Refer to the following diagram for general arrangement.

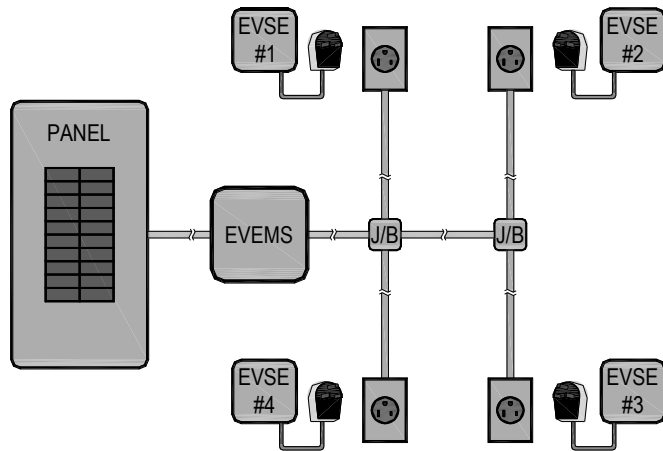

Figure 3: Rotational Load Management

Dynamic Load Management

Definition: Control of charging based on available capacity, and demand request at each EVSE.

Dynamic load management is the most flexible and efficient circuit sharing configuration as power delivery is based on actual requirement at each EVSE. The configuration provides ability to leverage specific demand at each EVSE to maximize power transfer. Disadvantages include increased EVSE costs, proprietary systems, prevalence of service fees, and reduced charging performance compared to dedicated EVSE. A site controller (either integral to the EVSE or standalone) with communications to a remote server is typically required. Refer to the following diagram for general arrangement.

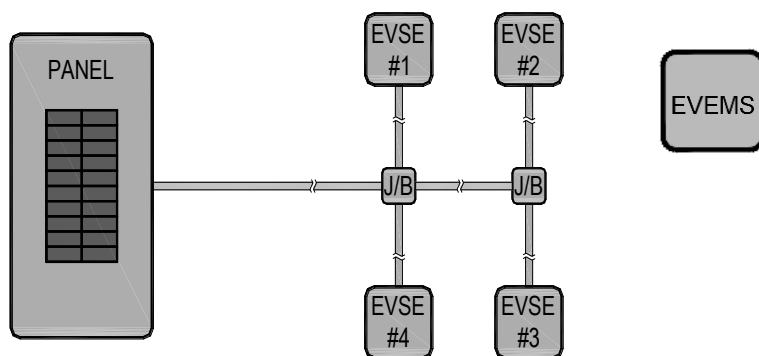

Figure 4: Dynamic Load Management

2.4 Panel Load Management

Definition: Control of charging based on available capacity of a panel.

Panel load management is commonly referred to as *panel sharing*, as charging is based on sharing the capacity of a specific panel. The configuration may, or may not, include circuit sharing. A demand factor of 100% is required, as per CSA C22.1-15. Allowance for diversity is permitted in accordance with Rule 8-106(10) (*Appendix D*) of CSA C22.1-18, when adopted. Reduction in electrical system infrastructure is achievable, dependent on the number of EVSE per panel. Panel sharing alone does not achieve maximum efficiency of electrical infrastructure.

Disadvantages are the same as for dynamic load management. Refer to the following diagram for general arrangement.

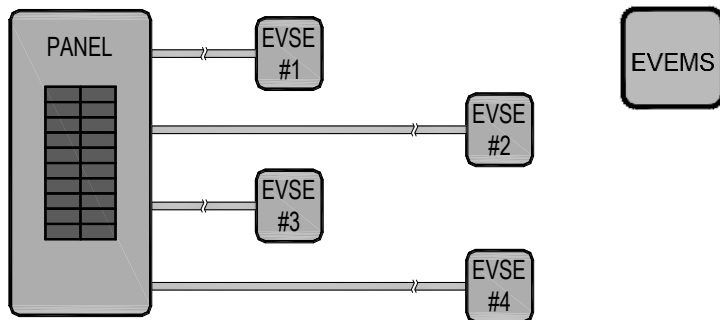

Figure 5: Panel Load Management

2.5 Dwelling Demand Load Management

Definition: Control of charging based on available capacity for a dwelling.

Dwelling demand load management connects to the feeder supplying a dwelling unit to control charging according to available spare capacity. A demand factor of 100% is required, as per CSA C22.1-15. Allowance for diversity is permitted in accordance with Rule 8-106(10) (*Appendix D*) of CSA C22.1-18, when adopted. Reduction in electrical system infrastructure is achievable, dependent on the number of EVSE per dwelling unit.

The configuration is appropriate where the utility meter for the dwelling unit is located within a reasonable distance to the parking stall. This generally represents low rise apartment buildings and townhouses, and not medium and high rise MURBs. Controllers typically operate independently, and without communication with the EVSE.

Advantages of the configuration include avoidance of metering issues, design simplicity, ease of system setup, avoidance of service fees, and avoidance of proprietary requirements for EVSE. Disadvantages include concerns associated with switching input power to EVSE, random delay of charging of EVSE upon power return, inability to identify a defective charger, and space requirements for controllers (particularly where multiple units are involved). Refer to the following diagram for general arrangement.

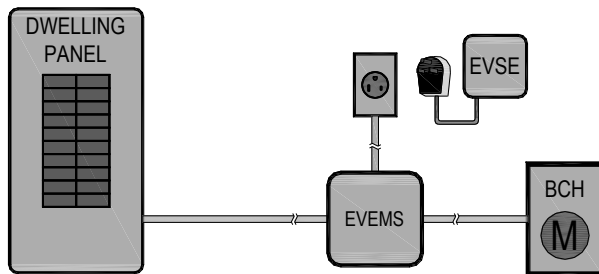

Figure 6: Dwelling Demand Load Management

2.6 Building Demand Load Management

Definition: Control of charging based on available capacity for a building.

Building demand load management monitors building spare capacity to control charging. The configuration also features panel and circuit sharing. A demand factor of 100% is required, as per CSA C22.1-15. Allowance for diversity is permitted in accordance with Rule 8-106(11) (*Appendix D*) of CSA C22.1-18, when adopted. The configuration represents the greatest opportunity for reduction in electrical system infrastructure, dependent on the number of EVSE for the building. Such systems also feature circuit sharing capabilities.

Advantages of the configuration include optimum utilization of electrical infrastructure and hence lowest electrical infrastructure costs, and increased monitoring and control features. Disadvantages include increased product costs, limited number of manufacturers, increased complexity of design, proprietary systems, and reduced charging performance compared to dedicated EVSE.

Due to the complexity of the systems, code issues (resolved in CSA C22.1-18), certification challenges, and patent issues, very few suppliers currently offer solutions that achieve this configuration. There are however, a number of installed systems and the prevalence is expected to increase as the technology matures. Refer to the following diagram for general arrangement.

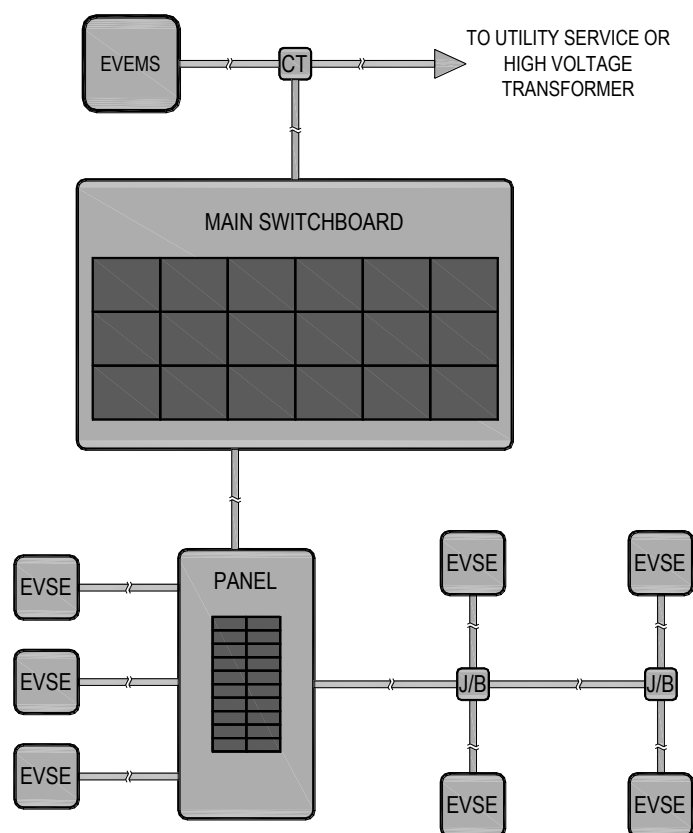

Figure 7: Building Demand Load Management

Refer to configuration table (*Appendix A*) for further details. Refer to the following section for product comparisons.

3.0 COMPARISONS

3.1 General

The following section identifies relevant product comparison criteria. Refer to the product comparison table (*Appendix B*) for further details.

3.2 Mounting Option

EVSE are typically designed as a base model with no mounting hardware. Mounting hardware specific to the installation is specified separately. Typical mounting options include:

- wall;
- pedestal;
- ceiling;
- portable.

3.3 Charging Ports

EVSE typically has a single charging port. A number of manufacturers offer mounting hardware to accommodate two or more units, often to appear as integrated equipment. Unless a dual port product is supplied from a single branch circuit, the product is categorized as single port.

- single – EVSE accommodates one charging port;
- dual – EVSE accommodates two charging ports.

Dual port devices that share power must be approved for load sharing of the circuit.

3.4 Circuit Rating and Output Ampacity

EVSE models are typically designed as a base model with a standard circuit rating and output ampacity. A number of EVSE models provide field adjustable settings to accommodate power supply from reduced circuit ratings. For simplicity, the comparison data does not include every variant of such models.

3.5 Cost

Prices are based on information provided by suppliers and/or advertised purchase price from online retailers. Cost savings can be expected for large quantities, particularly where specific contract negotiations are conducted with suppliers.

3.6 Certification

Products are typically certified to *C22.2 NO. 280-16 - Electric vehicle supply equipment (Tri-national standard, with UL 2594 and NMX-J-677-ANCE-2016)* by certification agencies such as CSA, Interlink (cETL), or UL (cUL). Products solely certified to *UL 2594* can typically also be certified to CSA due to harmonized CSA and UL standards. These standards do not address load sharing.

3.7 Questionnaire

To encourage consistent and detailed information from suppliers of load management products, a questionnaire was utilized. With load management technology in relative infancy, documentation is typically limited or unavailable, and the questionnaire assisted in achieving improved efficiency of communications and consistency. Refer to the questionnaire for further details.

3.8 Potential Solutions

All configurations types indicated in Section 2 are potential solutions for provision of EV charging. Some are more conducive to specific building/facility types, as highlighted in *Appendix A*. In general, load management, regardless of the type, provides considerable cost savings compared to dedicated circuits, particularly as the number of EVSE increases.

Greatest cost savings are available from Building Demand Load Management, as capacity requirements may be reduced, and variance of building demand leveraged, to maximize efficiency of the EVSE infrastructure. The concern with Building Demand Load Management is the limited number of currently available products, compared to Dynamic Load Management. Only time will determine whether the industry progresses towards Building Load Management, and if so, how rapid the progression will be.

As highlighted in the report completed for the City of Richmond by AES Engineering, titled *Electric Vehicle Charging Infrastructure in New Multifamily Developments – Requirement Options and Costing Analysis*, a cost-effective solution is a 40A 208V connection to each parking stall, with circuit sharing of up to four stalls per branch circuit, or equivalent (additional chargers on a circuit of greater ampacity). With a larger capacity branch circuit there is the ability to leverage higher efficiencies and hence reduced costs inherent with an increased sharing population, until the point where the circuit breaker, panel, and cabling costs of the increased capacity branch circuits counters the gains.

General recommendation, without performing analysis of the electrical system of the specific building, is for implementation of dynamic load management for all MURBs comprising greater than 5 parking stalls. Dwelling Demand Load management is typically appropriate for consideration for low-rise MURBs where all apartment electrical meters are located within the main electrical room. It is cautioned that each building and associated electrical system differs, and electrical engineering engagement is recommended to determine the most appropriate solutions and prepare appropriate design drawings.

4.0 DELIVERY MODELS

4.1 General

Delivery models for EVSE are evolving as the market matures. For new construction, with introduction of municipality charging requirements, prevalence of electrical infrastructure installation for EVSE as part of building construction is increasing. This generally means the costs are borne by the developer. The cost of EVSE is typically borne by the resident. A limited number of developers are installing both the electrical infrastructure and EVSE as part of building construction. For existing buildings costs of both the electrical infrastructure and EVSE are typically borne by the resident.

Some manufacturers and utilities are developing arrangements whereby all installation costs are covered by the manufacturer, with costs recovered through service fees for long term contracts. Such arrangements are uncommon but increasing in popularity and may represent a future whereby business models transition to service based. Also anticipated are contracts that cover an entire building or portfolio of buildings similar in nature to internet and cable television services. As agreements are variable, constantly changing, and often specific to a particular building, detailed information is not appropriate for this report; and highlights the importance of engaging an electrical engineer to assess the issues related to the specific building, in order to achieve the most appropriate solutions.

Refer to the following section for details of the required variance process for load management EVSE.

5.0 VARIANCE PROCESS

5.1 General

An approvals process is required for installation of EVSE with load management capabilities. This includes all EVSE; from the simplest static load management configuration with two EVSE to the most complex Building Demand Load Management systems. Code/AHJ approval is required for electrical installations, with a few exceptions such as electric utility companies. Amendments to the 2018 electrical code clarify the permission and requirements in terms of the use of load management systems. Major additions include Rule 8-106(10) and 8-106(11) (*Appendix D*) which permit maximum demand to be calculated in accordance with load management system settings, and where main service monitoring is performed, demand load of EVSE is not required to be considered. Until the 2018 code (CSA C22.1-18) is adopted (reasonably expected in early 2019), interim approvals processes are required to achieve AHJ approvals. Interim approvals processes also address the product approvals issue (see below). Refer to *Appendix D* for details of the 2018 code amendments.

The electrical code (CSA C22.1-15 Canadian Electrical Code, Part I) mandates that only approved equipment may be used in electrical installations. Approved equipment is defined as *equipment that has been certified by a certification organization accredited by the Standards Council of Canada in accordance with the requirements of CSA or other recognized documents, where CSA standards do not exist or are not applicable, or equipment that conforms to the requirements of the regulatory authority.* There is currently no CSA (Canadian Standards Association) standard for load management of EV chargers, therefore certification laboratories have no basis for testing and certification, certification is not occurring, and regulatory authorities had not previously permitted installation.

CSA plans to assemble a working group to prepare an appropriate standard, to rectify the problem. The initial exercise in the process is the development of a seed document to form the basis of the standard development. It is important that CSA prepare the standards document as soon as possible to resolve the issue.

The approvals processes for City of Vancouver and Technical Safety BC differ slightly, with both still under development and subject to modification as the process matures, but the basics steps are as follows.

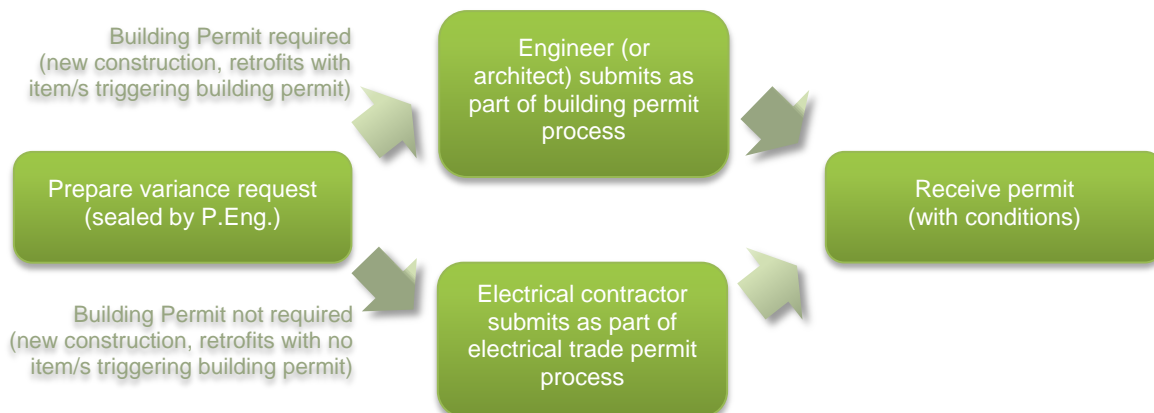

Figure 8: Approvals Process

Both the Technical Safety BC and City of Vancouver processes are pursuant to Rule 2-030 (Deviation or postponement) of the electrical code. The Technical Safety BC form is a dedicated form (Request for Variance) for EVSE load management and the City of Vancouver form is the general Request for Special Permission form. Conditions applied to the variance include:

- load calculations are submitted;
- sealed engineering drawings are submitted;
- details of proposed EVSE are provided;
- BC Hydro is notified of the increased load;
- commissioning demonstrates safe operation in all modes of operation (both normal and abnormal);
- an operating permit is obtained;
- associated fees are paid.

Refer to *Appendix E* for copies of the forms and the draft information bulletin associated with the Technical Safety BC form. Municipalities with their own inspections departments (such as the City of Burnaby, District of North Vancouver, etc.) will need to address the issue of approvals for load management, in a similar manner to the City of Vancouver and Technical Safety BC.

Refer to the following section for details of user fee assignment and electricity cost reconciliation.

6.0 KEY CONSIDERATIONS FOR STRATA BYLAWS AND/OR RULES

6.1 General

This section comprises of a checklist of issues to consider for strata corporation bylaws and/or rules that pertain to EV charging. It should not be treated as case specific legal advice, and engagement of legal advice is recommended when preparing bylaw amendments. Additional information pertinent to strata bylaws that address EV charging is included in *Appendix F*. Bylaws which apply to EVSE are very much dependent on how the parking is held, who is initiating the use and installation, and whether the building has the capacity to manage demand. Below is a checklist of issues to consider for strata corporation bylaws that deal with EVSE.

It is important to keep in mind that a strata corporation may amend its bylaws by a 3/4 vote under Section 128 of the *Strata Property Act*. In a situation in which a municipality were to require a developer to put 100% EVSE in new builds, it is still possible that a strata corporation could amend its bylaws and decommission or prevent use of EVSE. Instead, a municipality could require a developer to enter into a covenant under Section 219 of the *Land Title Act*, which requires the owner of the land to keep the EVSE in operation. The covenant would be binding on the strata corporation.

6.2 List of Issues

The following is a list of issues to include in strata corporation bylaws related to EVSE:

Where an owner, occupant, or tenant is requesting the right to install EVSE in a common property stall which is for the exclusive use of that owner:

- require the owner, occupant, or tenant to obtain consent from the strata corporation prior to the installation;
- if the strata corporation has adopted an energy management system, require that installation, use and removal of EVSE occur in accordance with the energy management system as it may be updated or replaced from time-to-time and that only EVSE approved for use with the energy management system may be used;
- if the strata corporation has not already adopted an energy management system, require the owner, occupant, or tenant to provide the strata corporation a written description of the proposed EVSE, the proposed design and installation, the name of the party doing the installation and any other documents or plans requested by the Strata Council;
- require the owner, occupant, or tenant to sign an Alteration and Indemnity Agreement on terms to be determined by the Strata Council, including the following:
 - the owner, occupant, or tenant will obtain all necessary permits;
 - the owner, occupant, or tenant will pay for all installation costs and for the cost of all future repairs, maintenance, and upgrades;
 - the owner, occupant, or tenant will pay all costs required and take all actions necessary to comply with any existing or future energy management system selected for use by the Strata Council including replacing or modifying the owner, occupant, or tenant's EVSE, if necessary;
 - the owner, occupant, or tenant will comply with all applicable laws;
 - the owner, occupant, or tenant will retain qualified contractors for the purpose of installing the Charging Equipment;

- the owner, occupant, or tenant will indemnify and save harmless the Strata Corporation for any costs, loss or expense of whatever kind which the Strata Corporation may sustain in connection with the EVSE;
- require an owner, occupant, or tenant to pay a user fee. The amount of the user fee must be set out, but could be expressed as a fraction of total electricity costs. User fees could also be consumption based, contingent on Measurement Canada issues being addressed.

Where the strata corporation is installing EVSE for use in a common property stall which is used by multiple users:

- set out the amount of the user fee and how it will be charged and collected;
- set out how use of the parking stall will be used and managed, for example:
 - whether an owner, occupant or tenant will need to obtain consent and sign a user agreement before using the stall;
 - a maximum amount of time that an owner, occupant or tenant may use the stall;
 - whether or not visitors may park in the stall.

For additional information pertinent to strata bylaws, refer to *Appendix F*.

APPENDIX A: CONFIGURATIONS

Configuration	Feasibility	Relative Costs for Implementation	Relative Costs for Users	Compatible Providers	Ability to Sub-meter Electrical Costs at the EVSE	Recommended Installation
Dedicated Circuit	<ul style="list-style-type: none"> Substantial increase in electrical infrastructure to accommodate all EVSE loads Dedicated circuit to each outlet from distribution panel Typically, compatible with all EVSE models 	<ul style="list-style-type: none"> High infrastructure cost High wiring cost Low EVSE cost 	<ul style="list-style-type: none"> Owners may purchase any EVSE and at any time No subscription fee 	<ul style="list-style-type: none"> All EVSE manufacturers 	Optional	<ul style="list-style-type: none"> High turnover stalls such as car sharing Not recommended for assigned parking
Static Circuit Sharing	<ul style="list-style-type: none"> Cannot redistribute available circuit capacity when multiple EVs are charging at different rate Sufficient capacity is to be allocated for the maximum demand of the circuit Compatible EVSE models only 	<ul style="list-style-type: none"> Medium infrastructure cost Low wiring cost Medium EVSE cost 	<ul style="list-style-type: none"> Typically, no subscription fee 	<ul style="list-style-type: none"> Share2 (Sun Country Highway) JuiceBox Pro (eMotorWerks) EverCharge 	Optional	<ul style="list-style-type: none"> Visitor parking stalls Not recommended for assigned parking
Rotational (Time-Shared) Circuit Sharing	<ul style="list-style-type: none"> Potential unfair time allocation amongst EV owners Sufficient capacity is to be allocated for the maximum demand of the circuit Requires site controller No proprietary requirements for EVSE 	<ul style="list-style-type: none"> Medium infrastructure cost Medium wiring cost Low EVSE cost 	<ul style="list-style-type: none"> Potential subscription fee shared amongst users 	<ul style="list-style-type: none"> EV Master Controller (Cyber Switching Solutions) HYDRA-R (Liberty Plugins) 	Optional	<ul style="list-style-type: none"> Corporate fleet parking Not recommended for assigned parking
Dynamic Load Management	<ul style="list-style-type: none"> Allocates maximum available power to each connected EV Sufficient capacity is to be allocated for the maximum demand of the circuit Requires site controller Compatible EVSE models only 	<ul style="list-style-type: none"> Medium infrastructure cost Low wiring cost Medium/High EVSE cost 	<ul style="list-style-type: none"> Medium/High subscription cost 	<ul style="list-style-type: none"> CoRe+ PS (AddEnergie) CPF25 (ChargePoint) EVBox 	Optional	<ul style="list-style-type: none"> MURB
Panel Load Management	<ul style="list-style-type: none"> Sufficient capacity is to be allocated for the maximum demand of the panel/system Requires site controller Compatible EVSE models only 	<ul style="list-style-type: none"> Medium infrastructure cost High wiring cost Medium/High EVSE cost 	<ul style="list-style-type: none"> Medium/High subscription cost 	<ul style="list-style-type: none"> CoRe+ PS (AddEnergie) CPF25 (ChargePoint) 	Optional	<ul style="list-style-type: none"> MURB
Dwelling Demand Load Management	<ul style="list-style-type: none"> Derived circuit to each outlet from dwelling feeders EVSE load is included in each dwelling basic load May overload building service if EVSE loads exceed diversity factor Requires site controllers Typically, compatible with all EVSE models 	<ul style="list-style-type: none"> Low infrastructure cost Low/Medium wiring cost Low EVSE cost 	<ul style="list-style-type: none"> Owners may purchase any EVSE No subscription fee 	<ul style="list-style-type: none"> DCC Technology (rve) 	Power is supplied directly from the dwelling unit assigned to the parking stall	<ul style="list-style-type: none"> MURB
Building Demand Load Management	<ul style="list-style-type: none"> Requires signals from the BMS or installation of metering on the building's main switchboard Requires site controller Compatible EVSE models only 	<ul style="list-style-type: none"> Low infrastructure cost Low wiring cost Medium/High EVSE cost 	<ul style="list-style-type: none"> Medium/High subscription cost 	<ul style="list-style-type: none"> VariableGrid (IBX) PowerFlex (BTC Power) AddEnergie + TED (AddEnergie/TED) 	Optional	<ul style="list-style-type: none"> MURB by integrating with circuit and panel sharing

APPENDIX B: COMPARISON TABLES

EVEMS	Static Circuit Sharing	Time-Shared Circuit Sharing	Dynamic Circuit Sharing	Panel Sharing	Building Demand Load Management
CoRe+ PS (AddEnergie)	Y	Y	Y	Y	Y
PowerFlex (BTC Power)	Y	Y	Y	Y	N
CPF25 (ChargePoint)	Y	Y	Y	Y	Y
EVMC (Cyber Switching Solution)	N	Y	N	N	N
EV Box	Y	N	Y	N	N
EverCharge	Y	N	N	N	N
VariableGrid (IBX)	Y	Y	Y	Y	Y
HYDRA-R (Liberty Plugins)	N	Y	N	N	N
DCC Technology (rbe)	Y	N	N	N	N
Share2 (Sun Country Highway)	Y	N	N	N	N
JuiceBox Pro (eMotorWerks)	Y	N	N	N	N
EVSE LLC	Y	Y	Y	Y	N

* Price Per System: Cost of the EVEMS (load management) system in addition to EVSE costs.

* Annual Fee: Cost of annual service fee for monitoring, support and billing.

EVSE	EVSE Family Name	EVSE Model	Wall	Pedestal	Ceiling	Portable	Single	Dual	Breaker	Output	Enclosure	CSA	cETL	cUL	UL
ABB	n/a	n/a													
AddEnergie	FLO Home	G5	Y	N	N	N	Y	N	40 A	30 A	4X	Y	N	N	N
AddEnergie	FLO Home	X5	Y	N	N	N	Y	N	40 A	30 A	4X	Y	N	N	N
AddEnergie	Core+	Core+	Y	Y	N	N	Y	N	40 A	30 A	4X	Y	N	N	N
AddEnergie	Core+	Core+ PS	Y	Y	N	N	Y	Y	40 A	30 A	4X	Y	N	N	N
AddEnergie	SmartTWO	SmartTWO	Y	Y	N	N	Y	N	40 A	30 A	3R	Y	N	N	N
AeroVironment	EV Solutions	TurboCord	N	N	N	Y	Y	N	20 A	16 A	6P	N	N	Y	Y
AeroVironment	EV Solutions	EVSE-RS	Y	Y	N	N	Y	N	40 A	32 A	3R	N	N	Y	Y
AeroVironment	EV Solutions	EVSE-RS PLUG-IN	Y	Y	N	Y	Y	N	40 A	30 A	3R	N	N	Y	Y
AeroVironment	EV Solutions	TurboDock	Y	Y	N	N	Y	N	40 A	16 A	3R	N	N	Y	Y
Blink	Blink	Level 2	Y	Y	N	N	Y	N	40 A	30 A	3R	N	N	Y	Y
Bosch	Power Max 2	EL-51866-3018	Y	Y	N	N	Y	N	40 A	30 A	3R	N	N	Y	Y
Bosch	Power Max 2	EL-51866-4018	Y	Y	N	N	Y	N	50 A	40 A	3R	N	N	Y	Y
Bosch	Power Xpress	EL-50600-D	Y	Y	N	N	Y	N	40 A	32 A	4X	Y	N	N	N
Bosch	Power Max	EL-51253	Y	Y	N	N	Y	N	40 A	30 A	3R	N	N	Y	Y
ChargePoint	Home	CPH25	Y	N	N	N	Y	N	40 A	32 A	3R	N	N	Y	Y
ChargePoint	CPF25	CPF25	Y	Y	N	N	Y	Y	40 A	32 A	3R	N	N	Y	Y
ChargePoint	CT4000	CT4000	Y	Y	N	N	Y	Y	40 A	32 A	3R	N	N	Y	Y
Delta	Wallbox	Wallbox	Y	Y	N	N	Y	N	40 A	30 A	3R	N	N	Y	Y
Delta	Mini	Mini	Y	Y	N	N	Y	N	50 A	40 A	3R	N	N	Y	Y
Eaton	n/a	n/a													
Elmec	EVduty	EVC30	Y	N	N	N	Y	N	40 A	30 A	3R	N	N	Y	Y
Eluminocity	GridCharge	CH-21130	Y	Y	N	N	Y	N	40 A	30 A	3R	N	N	Y	Y
Eluminocity	GridCharge	CH-21140	Y	Y	N	N	Y	N	50 A	40 A	3R	N	N	Y	Y
eMotorWerks	JuiceBox	JuiceBox Pro 40	Y	N	N	Y	Y	N	50 A	40 A	4	N	N	Y	Y

EVSE	EVSE Family Name	EVSE Model	Wall	Pedestal	Ceiling	Portable	Single	Dual	Breaker	Output	Enclosure	CSA	cETL	cUL	UL
eMotorWerks	JuiceBox	JuiceBox Pro 75	Y	N	N	N	Y	N	100 A	75 A	4	N	N	Y	Y
EV Box	Elvi	Elvi	Y	N	N	N	Y	N	40 A	32 A	3R	N	N	Y	Y
EverCharge	EverCharge	EC001	Y	Y	N	N	Y	N	40 A	30 A	3R	N	N	Y	Y
EVoCharge	EVoCharge	EV072	Y	N	N	N	Y	N	40 A	30 A	3R	N	N	Y	N
EVoCharge	EVoCharge	EVO30	Y	Y	Y	N	Y	N	40 A	30 A	3R	N	Y	Y	N
EVSE LLC	EVSE LLC	3703 ChargeWorks	Y	Y	N	N	Y	N	40 A	30 A	3R	Y	N	N	Y
EVSE LLC	EVSE LLC	3704 AutoCoil	Y	Y	N	N	Y	N	40 A	30 A	3R	Y	N	N	Y
EVSE LLC	EVSE LLC	3722 Garage Overhead	N	N	Y	N	Y	N	40 A	30 A	3R	Y	N	N	Y
GE	n/a	n/a													
JuiceBar	Mini Bar	Mini Bar Single	Y	Y	N	N	Y	N	40 A	30 A	3R	N	Y	N	N
Leviton	Evr-Green	EVBL2	N	N	N	Y	Y	N	30 A	20 A	3R	N	N	Y	Y
Leviton	Evr-Green	EVR30	Y	N	N	N	Y	N	40 A	30 A	3R	N	N	Y	N
Leviton	Evr-Green	EVR40	Y	N	N	N	Y	N	50 A	40 A	3R	N	N	Y	Y
PowerPost	L2	L2	Y	Y	N	N	Y	N	20 A	14 A	3R	N	N	Y	Y
Schneider Electric	n/a	n/a													
SemaConnect	500 Series	500 Series	Y	Y	N	N	Y	Y	40 A	30 A	3R	Y	N	N	N
SemaConnect	620 Series	620 Series	Y	Y	N	N	Y	Y	40 A	30 A	3R	Y	N	N	N
Siemens	VersiCharge	VC30XXXU	Y	N	N	N	Y	N	40 A	30 A	4	Y	N	Y	N
Siemens	VersiCharge	VC30XXXHW	Y	N	N	N	Y	N	40 A	30 A	1	Y	N	Y	N
SunCountryHighway	SCH	SCH15	Y	Y	N	N	Y	N	15 A	12 A	4	N	Y	Y	Y
SunCountryHighway	SCH	SCH20	Y	Y	N	N	Y	N	20 A	16 A	4	N	Y	Y	Y
SunCountryHighway	SCH	SCH25	Y	Y	N	N	Y	N	25 A	20 A	4	N	Y	Y	Y
SunCountryHighway	SCH	SCH30	Y	Y	N	N	Y	N	30 A	25 A	4	N	Y	Y	Y
SunCountryHighway	EV	EV40	Y	Y	N	N	Y	N	40 A	32 A	4	N	Y	Y	N
SunCountryHighway	EV	EV50	Y	Y	N	N	Y	N	50 A	40 A	4	N	Y	Y	N

EVSE	EVSE Family Name	EVSE Model	Wall	Pedestal	Ceiling	Portable	Single	Dual	Breaker	Output	Enclosure	CSA	cETL	cUL	UL
SunCountryHighway	EV	EV60	Y	Y	N	N	Y	N	60 A	48 A	4	N	Y	Y	N
SunCountryHighway	SCH	SCH40	Y	Y	N	N	Y	N	40 A	32 A	4	N	Y	Y	Y
SunCountryHighway	EV	EV40 Share2	Y	N	N	N	N	Y	40 A	32 A	4	N	Y	Y	N
SunCountryHighway	SCH	SCH60	Y	Y	N	N	Y	N	60 A	48 A	4	N	Y	Y	Y
SunCountryHighway	SCH	SCH100	Y	Y	N	N	Y	N	100 A	80 A	4	N	Y	Y	Y
WattZilla	Wall Wattz	40-AMP	Y	N	N	N	Y	N	50 A	40 A	4x	N	N	Y	Y
WattZilla	Wall Wattz	48-AMP	Y	N	N	N	Y	N	60 A	48 A	4x	N	N	Y	Y
WattZilla	Wall Wattz	75-AMP	Y	N	N	N	Y	N	100 A	75 A	4x	N	N	Y	Y
WattZilla	Uno	Uno	Y	N	N	N	Y	N	100 A	80 A	4x	N	N	Y	Y

APPENDIX C: LOAD MANAGEMENT (EVEMS) QUESTIONNAIRE

No.	Term	Definition
1.	<i>EVSE</i>	Electrical Vehicle Service Equipment, as defined in CSA C22.1-18
2.	<i>EVEMS</i>	Electrical Vehicle Energy Management System, as defined in CSA C22.1-18
3.	<i>Load Management</i>	The underlying technology of the <i>EVEMS</i>
4.	<i>Server</i>	The physical device (or cluster of devices) which hosts the <i>EVEMS</i> software
5.	<i>Cloud</i>	A <i>Server</i> that is located remotely (off-site)
6.	<i>Gateway</i>	A physical device that consolidates the signals from each <i>Station</i> and communicates with the <i>Server</i>
7.	<i>Station</i>	A single or group of <i>EVSE</i> that share a common communications device
8.	<i>Master</i>	An arbitrarily assigned <i>Station</i> that serves the function of the <i>Gateway</i>
9.	<i>Slave</i>	A <i>Station</i> that communicates with the <i>Server</i> via the <i>Master</i>
10.	<i>LAN</i>	Physically connected Local Area Network
11.	<i>WLAN</i>	Wireless <i>LAN</i> (i.e. Wi-Fi), as per IEEE 802.11
12.	<i>ZigBee</i>	A form of WPAN, as per IEEE 802.15.4

No.	Question	Response
A. Characteristics		
1.	What is the name of manufacturer?	
2.	What is the name of the <i>EVEMS</i> ? (if applicable)	
3.	What models are supported by the <i>EVEMS</i> ?	
4.	Does the <i>EVSE</i> support third-party <i>EVEMS</i> ? If so, which?	
B. Certifications		
1.	Is the <i>EVEMS</i> certified or pending certification? Note this refers to the certification of the <i>EVEMS</i> and not the <i>EVSE</i> .	Note that a CSA Standard is not yet available.
2.	If so, to what UL/CSA standard?	Note that a CSA Standard is not yet available.
3.	Has a variance (as per CEC Rule 2-030) been successfully applied with Technical Safety BC or City of Vancouver for the use of the <i>EVEMS</i> ?	
C. Communications		
1.	Does the system require a <i>Gateway</i> ?	
2.	Does the system require a <i>Master/Slave</i> configuration?	
3.	Can any <i>Station</i> be re-assigned (manually or automatically) as the <i>Master</i> after initial installation?	
4.	What are the modes of communications between the <i>Gateway</i> and the <i>Server</i> ?	e.g. <i>LAN</i> , Wi-Fi, GSM, CDMA, and/or other.
5.	What are the modes of communications between the <i>Gateway</i> and the <i>Stations</i> ?	e.g. <i>LAN</i> , RS-485, Wi-Fi, <i>ZigBee</i> , Bluetooth, and/or others.
6.	How many <i>Stations</i> can be controlled from one <i>Gateway</i> ?	
7.	What is the distance limitation from the <i>Gateway</i> to each <i>Station</i> for each mode of communications that is supported?	
8.	Can each <i>Station</i> become a signal extender?	
9.	Can the <i>EVEMS</i> use an existing <i>LAN</i> or <i>WLAN</i> as network infrastructure?	

No.	Question	Response
D. Fail-Safe Mechanism		
1.	Are there fail-safe mechanisms in the event of communications failure?	
2.	Are the mechanisms software and/or hardware?	
3.	In the event of power returning from an outage, what is the default setting (in terms of the <i>EVEMS</i>)?	e.g. rebaLANce the output current to each <i>EVSE</i> depending on the connected load at the moment of return of power.
4.	In the event of communications loss between a <i>Station</i> and the <i>Gateway</i> , what is the default setting?	e.g. the <i>Station</i> which lost communications assumes zero output current
5.	In the event of communications loss between the <i>Gateway</i> and the <i>Server</i> , what is the default setting?	e.g. all connected <i>EVSE</i> assumes a default output current that, when aggregated with all installed <i>EVSE</i> , will not overload the electrical system
6.	What other modes of failure are anticipated and what are the default fail-safe settings?	e.g. communications loss between the <i>Station</i> and the <i>Gateway</i>
7.	Can the fail-safe settings be configured after initial installation?	
E. Server		
1.	Where is the <i>Load Management</i> algorithm executed?	e.g. at each <i>Station</i> , on a local <i>Server</i> , on the <i>Cloud</i> , a mixture, and/or other
2.	What is the minimum bandwidth requirement?	e.g. 100 Mbps.
3.	Where is the <i>Cloud Server</i> ? (if applicable)	e.g. in Canada, in the US, and/or other
F. Operation		
1.	What level of <i>Load Management</i> is supported?	e.g. <ul style="list-style-type: none"> • At Branch Circuit level • At Panelboard level • At Electrical Service level • Other
2.	What is the operation of the <i>Load Management</i> ?	e.g. <ul style="list-style-type: none"> • In defined steps (1A increment) • Dynamically adjusted (continuous increment) • Turn-based • Mixture • Other

No.	Question	Response
G. Metering		
1.	What are the connection options for the metering?	e.g. Integral and/or External
2.	Is utility grade metering available?	
H. Fees		
1.	Is there a service fee associated with the <i>EVEMS</i> ?	
2.	How is the fee calculated?	e.g. base amount plus per <i>Station</i> and/or per User
3.	What services are available?	e.g. billing, maintenance, troubleshoot, software upgrade, etc.
I. Other		
1.	Is the <i>EVEMS</i> OCPP compliant?	
2.	Other features of the <i>EVEMS</i> not listed above.	
3.	Other features of the <i>EVEMS</i> not listed above.	

8-104 Maximum circuit loading (see Appendix B)

- 1) The ampere rating of a consumer's service, feeder, or branch circuit shall be the ampere rating of the overcurrent device protecting the circuit or the ampacity of the conductors, whichever is less.
- 2) The calculated load in a circuit shall not exceed the ampere rating of the circuit.
- 3) The calculated load in a consumer's service, feeder, or branch circuit shall be considered a continuous load unless it can be shown that in normal operation it will not persist for
 - a) a total of more than 1 h in any 2 h period if the load does not exceed 225 A; or
 - b) a total of more than 3 h in any 6 h period if the load exceeds 225 A.
- 4) A load of a cyclic or intermittent nature shall be classified as continuous unless it meets the requirements of Subrule 3).
- Δ 5) Where a fused switch or circuit breaker is marked for continuous operation at 100% of the ampere rating of its overcurrent devices, the continuous load as determined from the calculated load shall not exceed the continuous operation marking on the fused switch or circuit breaker and
 - a) except as required by Item b), shall not exceed 100% of the allowable ampacities of conductors selected in accordance with Section 4; or
 - b) shall not exceed 85% of the allowable ampacities of single conductors selected in accordance with Section 4.
- Δ 6) Where a fused switch or circuit breaker is marked for continuous operation at 80% of the ampere rating of its overcurrent devices, the continuous load as determined from the calculated load shall not exceed the continuous operation marking on the fused switch or circuit breaker and
 - a) except as required by Item b), shall not exceed 80% of the allowable ampacities of conductors selected in accordance with Section 4; or
 - b) shall not exceed 70% of the allowable ampacities of single conductors selected in accordance with Section 4.
- Δ 7) The continuous load as determined from the calculated load connected to a cablebus shall not exceed the values specified in Subrule 5) or 6).

Δ 8-106 Use of demand factors (see Appendix B)

- 1) In any case other than a service calculated in accordance with Rules 8-200 and 8-202, where the design of an installation is based on requirements in excess of those given in this Section, the service and feeder capacities shall be increased accordingly.
- 2) Where two or more loads are installed so that only one can be used at any one time, the one providing the greatest demand shall be used in determining the calculated demand.
- 3) Where it is known that electric space-heating and air-conditioning loads are installed and will not be used simultaneously, whichever is the greater load shall be used in calculating the demand.
- 4) Where a feeder supplies loads of a cyclic or similar nature such that the maximum connected load will not be supplied at the same time, the ampacity of the feeder conductors shall be permitted to be based on the maximum load that may be connected at any one time.
- 5) Where a feeder or service supplies motor or air-conditioning loads, a demand factor as determined by a qualified person shall be permitted to be applied to these loads, provided that a deviation has been allowed in accordance with Rule 2-030.
- 6) The ampacity of conductors of feeders or branch circuits shall be in accordance with the Section(s) dealing with the respective equipment being supplied.
- 7) Notwithstanding the requirements of this Section, the ampacity of the conductors of a feeder or branch circuit need not exceed the ampacity of the conductors of the service or of the feeder from which they are supplied.
- 8) Where additional loads are to be added to an existing service or feeder, the augmented load shall be permitted to be calculated by adding the sum of the additional loads, with demand factors as permitted by this Code, to the maximum demand load of the existing installation as measured over

- the most recent 12-month period, but the new calculated load shall be subject to Rule 8-104 5) and 6).
- 9) For loads other than those calculated in accordance with Rules 8-200 and 8-202, feeder and service load calculations shall be permitted to be based on demonstrated loads, provided that such calculations are performed by a qualified person, as determined by the regulatory authority having jurisdiction.
 - 10) Where electric vehicle supply equipment loads are controlled by an electric vehicle energy management system, the demand load for the electric vehicle supply equipment shall be equal to the maximum load allowed by the electric vehicle energy management system.
 - 11) For the purposes of Rules 8-200 1) a) vi), 8-202 3) d), 8-204 1) d), 8-206 1) d), 8-208 1) d), and 8-210 c), where an electric vehicle energy management system as described in Subrule 10) monitors the consumer's service and feeders and controls the electric vehicle supply equipment loads in accordance with Rule 8-500, the demand load for the electric vehicle supply equipment shall not be required to be considered in the determination of the calculated load.

8-108 Number of branch circuit positions

- 1) For a single dwelling, the panelboard shall provide space for at least the equivalent of the following number of 120 V branch circuit overcurrent devices, including space for two 35 A double-pole overcurrent devices:
 - a) 16 — of which at least half shall be double-pole, where the required ampacity of the service or feeder conductors does not exceed 60 A;
 - b) 24 — of which at least half shall be double-pole
 - i) where the required ampacity of the service or feeder conductors exceeds 60 A but does not exceed 100 A; or
 - ii) where the required ampacity of the service or feeder conductors exceeds 100 A but does not exceed 125 A and provision is made for a central electric furnace;
 - c) 30 — of which at least half shall be double-pole
 - i) where the required ampacity of the service or feeder conductors exceeds 100 A but does not exceed 125 A; or
 - ii) where the required ampacity of the service or feeder conductors exceeds 125 A but does not exceed 200 A and provision is made for a central electric furnace; and
 - d) 40 — of which at least half shall be double-pole, where the required ampacity of the service or feeder conductors exceeds 125 A and the dwelling is not heated by a central electric furnace.
- 2) Notwithstanding Subrule 1), sufficient spaces for overcurrent devices shall be provided in the panelboard for the two 35 A double-pole overcurrent devices and for all other overcurrent devices, and at least two additional spaces shall be left for future overcurrent devices.
- 3) For a dwelling unit in an apartment or similar building, the panelboard shall provide space for at least the equivalent of the following number of 120 V branch circuit overcurrent devices, including space for one 35 A double-pole overcurrent device:
 - a) 8 — where the required ampacity of the feeder conductors supplying the dwelling unit does not exceed 60 A; and
 - b) 12 — where the required ampacity of the feeder conductors supplying the dwelling unit exceeds 60 A.

8-110 Determination of areas

The living area designated in Rules 8-200 and 8-202 shall be determined from inside dimensions and include the sum of

- a) 100% of the area on the ground floor;
- Δ b) 100% of any areas above the ground floor used for living purposes; and

- Δ c) 75% of the area below the ground floor.

Δ **Calculated load for services and feeders**

8-200 Single dwellings (see Appendix B)

- Δ 1) The calculated load for the service or feeder supplying a single dwelling shall be based on the greater of Item a) or b):
- a)
- i) a basic load of 5000 W for the first 90 m² of living area (see Rule 8-110); plus
 - ii) an additional 1000 W for each 90 m² or portion thereof in excess of 90 m²; plus
 - iii) any electric space-heating loads provided for with demand factors as permitted in Section 62 plus any air-conditioning loads with a demand factor of 100%, subject to Rule 8-106 4); plus
 - iv) any electric range load provided for as follows: 6000 W for a single range plus 40% of any amount by which the rating of the range exceeds 12 kW; plus
 - v) any electric tankless water heaters or electric water heaters for steamers, swimming pools, hot tubs, or spas with a demand factor of 100%; plus
 - vi) except as permitted by Rule 8-106 11), any electric vehicle supply equipment loads with a demand factor of 100%; plus
 - vii) any loads provided for that have a rating in excess of 1500 W, in addition to those outlined in Items i) to vi), at
 - A) 25% of the rating of each load, if an electric range has been provided for; or
 - B) 100% of the combined load up to 6000 W, plus 25% of the combined load that exceeds 6000 W, if an electric range has not been provided for; or
- b)
- i) 24 000 W where the floor area, exclusive of the basement floor area, is 80 m² or more; or
 - ii) 14 400 W where the floor area, exclusive of the basement floor area, is less than 80 m².
- Δ 2) The calculated load for the consumer's service or feeder conductors supplying two or more dwelling units of row housing shall be based on
- a) the calculated load in the dwelling unit, as determined in accordance with Subrule 1), excluding any electric space-heating loads and any air-conditioning loads, with application of demand factors to the calculated loads as required by Rule 8-202 3) a) i) to v); plus
 - b) the requirements of Rule 8-202 3) b) to e).
- 3) Notwithstanding Rule 86-302, the total load calculated in accordance with either Subrule 1) or 2) shall not be considered to be a continuous load for application of Rule 8-104.

8-202 Apartment and similar buildings (see Appendix B)

- Δ 1) The calculated load for the service or feeder from a main service supplying loads in dwelling units shall be the greater of Item a) or b):
- a)
- i) a basic load of 3500 W for the first 45 m² of living area (see Rule 8-110); plus
 - ii) an additional 1500 W for the second 45 m² or portion thereof; plus
 - iii) an additional 1000 W for each additional 90 m² or portion thereof in excess of the initial 90 m²; plus
 - iv) any electric space-heating loads provided for with demand factors as permitted in Section 62 plus any air-conditioning loads with a demand factor of 100%, subject to Rule 8-106 4); plus
 - v) any electric range load provided for as follows: 6000 W for a single range plus 40% of any amount by which the rating of the range exceeds 12 kW; plus

- vi) any electric tankless water heaters or electric water heaters for steamers, swimming pools, hot tubs, or spas with a demand factor of 100%; plus
- vii) any loads provided for, in addition to those outlined in Items i) to vi), at
 - A) 25% of the rating of each load with a rating in excess of 1500 W, if an electric range has been provided for; or
 - B) 25% of the rating of each load with a rating in excess of 1500 W plus 6000 W, if an electric range has not been provided for; or
- b) 60 A.
- 2) The total load calculated in accordance with Subrule 1) and Subrule 3) a), b), and c) shall not be considered to be a continuous load for the application of Rule 8-104.
- Δ 3) The calculated load for the consumer's service or feeder supplying two or more dwelling units shall be based on the calculated load obtained from Subrule 1) a) and the following:
 - a) excluding any electric space-heating loads and any air-conditioning loads, the load shall be considered to be
 - i) 100% of the calculated load in the unit having the heaviest load; plus
 - ii) 65% of the sum of the calculated loads in the next 2 units having the same or next smaller loads to those specified in Item i); plus
 - iii) 40% of the sum of the calculated loads in the next 2 units having the same or next smaller loads to those specified in Item ii); plus
 - iv) 25% of the sum of the calculated loads in the next 15 units having the same or next smaller loads to those specified in Item iii); plus
 - v) 10% of the sum of the calculated loads in the remaining units;
 - b) if electric space heating is used, the sum of all the space-heating loads as determined in accordance with the requirements of Section 62 shall be added to the load determined in accordance with Item a), subject to Rule 8-106 4);
 - c) if air conditioning is used, the sum of all the air-conditioning loads shall be added, with a demand factor of 100%, to the load determined in accordance with Items a) and b), subject to Rule 8-106 4);
 - d) except as permitted by Rule 8-106 11), any electric vehicle supply equipment loads not located in dwelling units shall be added with a demand factor as specified in Table 38; and
 - e) in addition, any lighting, heating, and power loads not located in dwelling units shall be added with a demand factor of 75%.
- 4) The ampacity of feeder conductors from a service supplying loads not located in dwelling units shall be not less than the rating of the equipment installed with demand factors as permitted by this Code.

8-204 Schools

- Δ 1) The calculated load for the service or feeder shall be based on the following:
 - a) a basic load of 50 W/m² of classroom area; plus
 - b) 10 W/m² of the remaining area of the building based on the outside dimensions; plus
 - c) electric space-heating, air-conditioning, and total loads of other permanently connected equipment based on the rating of the equipment installed; plus
 - d) except as permitted by Rule 8-106 11), any electric vehicle supply equipment loads with a demand factor as specified in Table 38; plus
 - e) cord-connected equipment intended for connection to receptacles rated more than 125 V or 20 A based on
 - i) 80% of the rating of the receptacle; or
 - ii) the rating of the equipment intended for connection to the receptacle.

- 5) Parking lots that may be fully occupied under normal usage shall be assigned a greater demand load per space or stall.

Δ

Electric vehicle energy management systems

8-500 Electric vehicle energy management systems

- 1) Electric vehicle energy management systems shall be permitted to monitor electrical loads and to control electric vehicle supply equipment loads.
- 2) An electric vehicle energy management system shall not cause the load of a branch circuit, feeder, or service to exceed the requirements of Rule 8-104 5) or 6).
- 3) An electric vehicle energy management system shall be permitted to control electrical power by remote means.

Section 86 — Electric vehicle charging systems

Scope

86-000 Scope

- 1) This Section applies to the installation of
 - a) the insulated conductors and cables and the equipment external to an electric vehicle that connect it to a source of electric current by conductive or inductive means; and
 - b) equipment and devices related to electric vehicle charging.
- 2) This Section supplements or amends the general requirements of this Code.

General

86-100 Special terminology (see Appendix B)

In this Section, the following definitions shall apply:

Electric vehicle — an automotive-type vehicle for use on public roads that

- a) includes automobiles, buses, trucks, vans, low-speed vehicles, motorcycles, and similar vehicles powered by one or more electric motors that draw current from a fuel cell, photovoltaic array, rechargeable energy storage system (such as a battery or capacitor), or other source of electric current;
- b) includes plug-in hybrid electric vehicles (PHEVs); and
- c) excludes off-road electric vehicles, such as industrial trucks, hoists, lifts, transports, golf carts, airline ground support equipment, tractors, and mobility scooters for persons with disabilities.

Electric vehicle connector — a device that, when electrically coupled to a mating device on the electric vehicle, establishes means for power transfer and information exchange between an electric vehicle and electric vehicle supply equipment.

Δ **Electric vehicle supply equipment (EVSE)** — a complete assembly consisting of cables, connectors, devices, apparatus, and fittings installed for the purpose of power transfer and information exchange between the branch circuit and the electric vehicle.

Plug-in hybrid electric vehicle (PHEV) — a type of electric vehicle having an additional energy source for motive power.

86-102 Voltages

The nominal ac system voltages used to supply equipment covered in this Section shall not exceed 750 V.

86-104 Permanently connected and cord-connected equipment

Rules 86-300 to 86-404 apply to installation of permanently connected and cord-connected electric vehicle supply equipment.

Equipment

86-200 Warning sign

Permanent, legible signs shall be installed at the point of connection of the electric vehicle supply equipment to the branch circuit wiring, warning against operation of the equipment without sufficient ventilation as recommended by the manufacturer's installation instructions.

Control and protection

86-300 Branch circuits (see Appendix B)

- 1) Electric vehicle supply equipment shall be supplied by a separate branch circuit that supplies no other loads except ventilation equipment intended for use with the electric vehicle supply equipment.
- Δ 2) Notwithstanding Subrule 1), electric vehicle supply equipment shall be permitted to be supplied from a branch circuit supplying another load(s), provided that an electric vehicle energy management system is installed in accordance with Subrule 8-106 10) or 11).
- 3) For the purposes of Subrule 2), the calculated demand shall be determined in accordance with Section 8.

86-302 Connected load

The total connected load of a branch circuit supplying electric vehicle supply equipment and the ventilation equipment permitted by Rule 86-300 shall be considered continuous for the purposes of Rule 8-104.

86-304 Disconnecting means

- 1) A separate disconnecting means shall be provided for each installation of electric vehicle supply equipment rated at 60 A or more, or more than 150 volts-to-ground.
- 2) The disconnecting means required in Subrule 1) shall be
 - a) on the supply side of the point of connection of the electric vehicle supply equipment;
 - b) located within sight of and accessible to the electric vehicle supply equipment; and
 - c) capable of being locked in the open position.

86-306 Receptacles for electric vehicle supply equipment (see Appendix B)

- 1) Each receptacle for the purpose of electric vehicle charging shall be labelled in a conspicuous, legible, and permanent manner, identifying it as an electric vehicle supply equipment receptacle and shall be
 - a) a single receptacle of CSA configuration 5-20R supplied from a 125 V branch circuit rated not less than 20 A; or
 - b) of the appropriate CSA configuration in accordance with Diagram 1 or 2 when supplied from a branch circuit rated at more than 125 V or more than 20 A.
- 2) When the receptacle referred to in Subrule 1) a) is installed outdoors and within 2.5 m of finished grade, it shall be protected with a ground fault circuit interrupter of the Class A type.

86-308 Electric vehicle as electric power production source

- Δ 1) Electric vehicle supply equipment and other parts of a system, either on board or off board the vehicle, that are identified for and intended to be interconnected to a vehicle and also serve as an optional standby system or an electric power production source or provide for bi-directional power feed shall be marked accordingly.
- 2) When an electric vehicle is used as described in Subrule 1), the requirements of Section 84 shall apply.

Electric vehicle supply equipment locations

86-400 Indoor charging sites (see Appendix B)

- 1) Indoor sites shall be permitted to include, but not be limited to, integral, attached, and detached residential garages, enclosed or underground parking structures, repair and non-repair commercial garages, agricultural buildings, and similar rooms or locations where the electric vehicle connector can couple to the electric vehicle.
- 2) Where the electric vehicle supply equipment requires ventilation,
 - a) adequate ventilation shall be provided in each indoor charging site as specified in Rule 26-506;

Δ

Table 38
Electric vehicle supply equipment demand factors
 (See Rules 8-202 to 8-210.)

Number of automobile spaces or stalls per feeder	Maximum load per space or stall, W	Demand factor, %
1 to 4	2000	100
	4000	100
	6000	100
	8000 or more	100
5 to 8	2000	100
	4000	100
	6000	90
	8000 or more	90
9 to 12	2000	100
	4000	90
	6000	90
	8000 or more	80
13 to 16	2000	100
	4000	90
	6000	80
	8000 or more	80
17 to 24	2000	100
	4000	90
	6000	80
	8000 or more	70
25 and over	2000	100
	4000	90
	6000	70
	8000 or more	70

- c) electrical heating and cooking appliances (Rule 26-744); and
- d) other specific receptacles installed in dwellings, such as those dedicated for medical devices.

Rule 8-102 1) and Table D3 are applicable to these branch circuits excluded from Rule 8-102 3), based on either the connected load, or one load equal to 80% of the rating on the overcurrent device, connected at the furthest point.

It is intended by this Subrule that when the load on a circuit or feeder is unknown, the load value used in determining the voltage drop calculation should be based on the maximum loading permissible in accordance with Rule 8-104.

Further analysis has shown that these values will not affect the operation of the branch circuit overcurrent protection.

Rules 8-104 and 62-114

When an overcurrent device is located in an assembly such as a fused switch or a panelboard, the assembly is required to be marked for continuous operation of its overcurrent devices in accordance with the requirements of CSA C22.2 No. 4 or CSA C22.2 No. 29.

Fused switches and circuit breakers not marked as suitable for continuous operation at either 80% or 100% of the rating of their overcurrent devices are considered to be suitable for continuous operation at 80%.

Δ Rules 8-104 5) b) and 6) b)

It is intended that Subrule 5) b) or 6) b) be applied when the allowable ampacity of conductors is obtained from tables such as Table 1, 3, 12E, D8A, D8B, D9A, D9B, D17A, D17B, D17C, D17D, D17I, D17J, or D17M in accordance with Section 4.

Rule 8-106 9)

It is intended by this Subrule that demonstrated load data could be used for the purpose of sizing of services or feeders. It is also intended by this Subrule that the qualified person, as determined by the regulatory authority having jurisdiction, who is responsible for the design should be able, upon request, to demonstrate to the regulatory authority having jurisdiction that historical data related to actual demand substantiates the fact that this historical demand is the maximum possible demand for the specific application.

Δ Rule 8-106 11)

It is intended by this Rule that the loads of the electric vehicle supply equipment controlled by an electric vehicle energy management system should be considered to have a demand within the maximum limits allowed by the electric vehicle energy management system.

The electric vehicle energy management system is provided with a maximum load rating, which determines the branch circuit, feeder, and service loading.

Rules 8-200 and 8-202

If more than one electric range is involved, the initial range will be provided for according to Rule 8-200 1) a) iv) or 8-202 1) a) v), and any subsequent ranges will be provided for by Rule 8-200 1) a) vii) or 8-202 1) a) vii).

Rule 8-202

See the Note to Rule 8-200.

Rule 8-208

For the purpose of this Rule, a motel unit with cooking facilities may be considered an apartment.

APPENDIX E: VARIANCE FORMS



PLANNING & DEVELOPMENT SERVICES
Office of the Chief Building Official

Attachment to BULLETIN 2009-004-EL REQUEST FOR SPECIAL PERMISSION

The City Electrician
453 W 12th Avenue
Vancouver, B.C.
V5Y 1V4

Date: 2017/12/16
(YY MM DD)

Dear Sir: The following are the reasons for the request and supporting information

Address: 3585 Graveley Street, Vancouver
Electrical permit: EP-2017-10194
Building permit: N/A

To deviate from the following code requirements: Rule(s) 8-104(5), 8-104(6)

Reasons for request, summary of solutions and provide analysis and evaluation to validate acceptance:

The proposed electric vehicle energy management system meets the fundamental principles of protection for safety mandated by the CEC; and will not cause the load of the branch circuit, feeder, or service to exceed requirements of CEC Rules 8-104(5) and 8-104(6).

Refer to the attached pages for additional details.



FSR/Permit Holder *Near Energy Solutions Inc*

Affix Professional Seal (if applicable)

Company Name AES Engineering Ltd.

Name of the Registered Professional of record (if applicable) Royce Bernard

Signature *R. Bernard* Address 1330 Granville Street, Vancouver

Telephone (604) 365-0634 E-mail Royce.Bernard@AESengr.com

For CoV office use only

Request for Special permission is accepted: Yes No

For the City Electrician (name and the signature): *Blair Paul Lamb* *BL*

2018 January 15th

BULLETIN 2009-004-EL

Revised March 16, 2015

**APPLICATION OF RULE 2-030 OF THE CE CODE
PART I "DEVIATION OR POSTPONEMENT"**

This bulletin outlines the conditions under which an application for a Special Permission can be made to deviate from the prescriptive requirements of the Canadian Electric Code.

Rule 2-030 of the Canadian Electric Code (CEC) recognizes the fact that a deviation from the CEC prescriptive requirements could be allowed. Although Rule 2-030 clearly states that "if necessary", a Special Permission to deviate from the CEC requirements must be obtained before proceeding with the work and emphasizes that a Special Permission shall apply only for a particular installation for which it is given, it does not explain the criteria required for each such application.

The Object of Section 0 of the CEC addresses the fundamental principles of protection against electric shock, thermal effects, overcurrent, fault currents and overvoltage in electrical installations. Strict compliance with the prescriptive rules of the CEC is required to meet these fundamental safety principles and to provide an essentially safe installation.

However, it is acknowledged by the Object of Section 0 of the CEC that a safe installation may be also achieved by alternatives to this CEC requirement, where such alternatives meet the fundamental safety principles provided by the prescriptive rules of the CEC. Therefore, in accordance with provisions of Rule 2-030 each request for a deviation from the CEC requirements is considered by the City Electrician based on the following conditions:

1. A request for a Special Permission is made by using a generic application form (see attachment);
2. A request is submitted by the permit holder (FSR of an electrical contractor) or by the Electrical Registered Professional of record in respect to the specific permit number and to the specific installation only;
3. Each request provides a reference to the particular rules of the CEC from which a deviation is requested; and
4. Each request demonstrates a clear technical substantiation that a proposed alternative meets the fundamental safety principles of protection mandated by the CEC requirements from which a deviation is requested.

When a Special Permission is granted, a completed request form is signed by the City Electrician (or on his behalf) and returned to the applicant.

(Original signed by)

W. White
MANAGER, TRADES INSPECTION
DEPUTY CITY ELECTRICIAN

(Original signed by)

P. Ryan, M. Sc., P. Eng.
CHIEF BUILDING OFFICIAL
DIRECTOR, BUILDING CODE & POLICY

Attachment



REQUEST FOR SPECIAL PERMISSION – 3585 GRAVELEY STREET

Page 1 of 2

DATE:	December 16, 2017
BY:	Royce Bernard PEng, PE, RCDD, LEED AP

H:\PROJECTS\2017\2-17-235\LETTERS OF ASSURANCE\SP REQUEST_3585 GRAVELEY_AES_20171216_ATTACHMENT.DOCX

Under provisions of CSA C22.1-18, an energy management system is permitted for Electric Vehicle Supply Equipment (EVSE). The intent is to utilize energy management for this project under Rule 2-030 (provision for special permission). City of Vancouver has agreed to consider special permission for installation of energy management systems until such time as CSA C22.1-18 is adopted in BC. Refer to the attached code amendments for further details.

As CSA C22.1-15 does not provide a mechanism for the use of energy management systems for EVSE, there is no relevant CSA standard, and no certified equipment approved for load management. We understand CSA has commenced the process of development of an appropriate standard.

The EVSE is intrinsically safe, in accordance with testing and certification requirements. It is only the load management functions that have not been tested and certified in accordance with a recognized standard. In absence of a recognized standard, manufacturers implement various test procedures, including the use of electric vehicle (EV) simulators and/or connection of EV's. Scenarios, such as loss of communications and software failure are tested to ensure appropriate operation, and the proposal is to perform appropriate tests on site as part of the testing and commissioning process.

In a worst-case scenario, if failure were to occur, despite the mechanisms in place, and testing performed to prevent such events, the potential result would be overload of the circuit and operation of the associated overcurrent protection. Overcurrent protection is ultimately the final safety mechanism. The proposal to install multiple chargers on a branch circuit is analogous to installing multiple receptacles on a branch circuit. There are no restrictions to overloading of a receptacle circuit. With the proposal to install load management there are additional controls mechanism to restrict loading, in accordance with the requirements for continuous loads (Rules 8-104(5) and 8-104(6), and as referenced by Rule 86-302).



Load management systems monitor circuit loading and restrict charging accordingly. The specific load management associated with the proposed installation at 3585 Graveley Street includes failsafe timers in the server (communicating with the EVSE) and integral to each EVSE. If communications are lost, charging is immediately suspended.

Access to configuration and settings of the load management system is restricted to an administrator to ensure users are unable to make changes. Appropriate settings are configured to suit the installed electrical infrastructure during testing and commissioning by the electrical contractor and/or manufacturer/supplier's representative. Whether further restriction of access to system settings to trained and certified personnel is warranted, is to be determined.

With all such installations of EVSE with load management, the proposal is to perform detailed site tests to ensure the systems function as required, and in accordance with the relevant 2018 Code amendments (attached). The following site tests are proposed to be performed:

- Simulation of communications failure at each charger;
- Disconnection and reconnection of each charger;
- Load tests, commencing with no charging, and incrementally adding load (EV's), to achieve maximum loading, and then incrementally removing loads;
- Random loading tests;
- Sustained loading tests (period of two hours or more);

We understand that additional field inspection/s and/or requirements may be applied by the City of Vancouver to ensure implementation of energy management systems for EVSE does not compromise safety of the equipment and installation.

We trust this provides sufficient information for the *Request for Special Permission*. Should additional, or more detailed, information be required to achieve an appropriate level of understanding and comfort with load management technologies, we suggest that perhaps one of the current proposed projects (potentially 3585 Graveley Street, as it is a City of Vancouver owned site) form the basis of a pilot approvals process.

Subject No. 4166

(A) Add new definitions to Rule 8-002

Rule 8-002 Special terminology (see Appendix B)

Control of electric vehicle supply equipment loads – the process of connecting, disconnecting, increasing, or reducing electric power to electric vehicle supply equipment loads .

Electric Vehicle Energy Management System – a means of controlling electric vehicle supply equipment loads comprised of any of the following: a monitor(s), communications equipment, a controller(s), a timer(s) and-other applicable device(s).

(B) Add New Subrules 8-106(11) and (12)

8-106 Use of demand factors (see Appendix B)

(11) Where electric vehicle supply equipment loads are controlled by an Electric Vehicle Energy Management System, the demand load for the electric vehicle supply equipment shall be equal to the maximum load allowed by the Electric Vehicle Energy Management System.

(12) For the purposes of Rules 8-200(1)(a)(vi), 8-202(3)(d), 8-204(1)(d), 8-206(1)(d), 8-208(1)(d) and 8-210(b), where an Electric Vehicle Energy Management System described in 8-106(11), monitors the consumer's service and feeders and controls the electric vehicle supply equipment loads in accordance with Rule 8-500, the demand load for the electric vehicle supply equipment is not required to be considered in determination of the calculated load.

(C) Modify Item 8-200(1)(a)(vi)

8-200 Single dwellings (see Appendices B and I)

(1) The minimum ampacity of service or feeder conductors supplying a single dwelling shall be based on the greater of Item (a) or (b):

(a)

(vi) except as permitted by Rule 8-106(12) any electric vehicle supply equipment loads with a demand factor of 100%; plus

“

(D) Modify Item 8-202(3)(d)

8-202 Apartment and similar buildings (see Appendix B)

(3) The minimum ampacity of service or feeder conductors from a main service supplying two or more dwelling units shall be based on the calculated load obtained from Subrule (1)(a) and the following:

- (d) except as permitted by Rule 8-106(12), any electric vehicle supply equipment loads not located in dwelling units shall be added with a demand factor as specified in Table XY; and

“

(E) Modify 8-204

8-204 Schools

(1) The minimum ampacity of service or feeder conductors shall be based on the following:

- (a) a basic load of 50 W/m^2 of classroom area; plus
- (b) 10 W/m^2 of the remaining area of the building based on the outside dimensions; plus
- (c) electric space-heating, air-conditioning, and total loads of other permanently connected equipment based on the rating of the equipment installed; plus
- (d) except as permitted by Rule 8-106(12), any electric vehicle supply equipment loads with a demand factor as specified in Table XY; plus
- (e) cord-connected equipment intended for connection to receptacles rated more than 125 V or 20 A based on
 - (i) 80% of the rating of the receptacle; or
 - (ii) the rating of the equipment intended for connection to the receptacle.

“

(F) Modify 8-206

8-206 Hospitals

(1) The minimum ampacity of service or feeder conductors shall be based on the following:

- (a) a basic load of 20 W/m^2 of the area of the building based on the outside dimensions; plus
- (b) 100 W/m^2 for high-intensity areas such as operating rooms; plus
- (c) electric space-heating, air-conditioning, and total loads of other permanently connected equipment based on the rating of the equipment installed; plus
- (d) except as permitted by Rule 8-106(12), any electric vehicle supply equipment loads with a demand factor as specified in Table XY; plus
- (e) cord-connected equipment intended for connection to receptacles rated more than 125 V or 20 A based on
 - (i) 80% of the rating of the receptacle; or
 - (ii) the rating of the equipment intended for connection to the receptacle.

“

(G) Modify 8-208

8-208 Hotels, motels, dormitories, and buildings of similar occupancy (see Appendix B)

(1) The minimum ampacity of service or feeder conductors shall be based on the following:

- (a) a basic load of 20 W/m^2 of the area of the building, based on the outside dimensions; plus
- (b) lighting loads for special areas such as ballrooms, based on the rating of the equipment installed; plus
- (c) electric space-heating, air-conditioning, and total loads of other permanently connected equipment based on the rating of the equipment installed; plus
- [\(d\) except as permitted by Rule 8-106\(12\), any electric vehicle supply equipment loads with a demand factor as specified in Table XY; plus](#)
- [\(e\) cord-connected equipment intended for connection to receptacles rated more than 125 V or 20 A based on](#)
 - (i) 80% of the rating of the receptacle; or
 - (ii) the rating of the equipment intended for connection to the receptacle.

“

(H) Modify Item 8-210

8-210 Other types of occupancy

The minimum ampacity of service or feeder conductors for the types of occupancies listed in Table 14 shall be based on

- (a) a basic load in watts per square metre as required by Table 14 for the area of the occupancy served based on the outside dimensions of the occupancy, with application of demand factors as indicated in Table 14; plus
- (b) special loads such as electric space-heating, air-conditioning, motor loads, show window lighting, stage lighting, etc., based on the rating of the equipment installed with demand factors permitted by this Code; [plus](#)
- [\(c\) except as permitted by Rule 8-106\(12\), any electric vehicle supply equipment loads with a demand factor as specified in Table XY.](#)

(I) Add new Subsection for energy management systems

Electric vehicle energy management systems

8-500 Electric Vehicle Energy Management Systems

[\(1\) Electric vehicle energy management systems shall be permitted to monitor electrical loads and to control electric vehicle supply equipment loads.](#)

[\(2\) An electric vehicle energy management system shall not cause the load of a branch circuit, feeder, or service to exceed requirements of Rules 8-104\(5\) or 8-104\(6\).](#)

(3) An electric vehicle energy management system shall be permitted to control electrical power through the use of a remote means.

(J) Add Appendix B Note for Subrule 8-106(11)

Rule 8-106(11)

It is intended by this Rule that the loads of the electric vehicle supply equipment which are controlled by an electric vehicle energy management system, should be considered to have a demand within the maximum limits allowed by the electric vehicle energy management system.

The electric vehicle energy management system is provided with a maximum load rating which will determine the branch circuit, feeder and service loadings.

(K) Add new Table XY

Table XY
Electric vehicle supply equipment demand factors
(See Rules 8-202 - 8-210)

<u>Number of automobile spaces or stalls per feeder</u>	<u>Maximum load per space or stall (Watts)</u>	<u>Demand factor (%)</u>
<u>1 to 4</u>	<u>2000</u>	<u>100</u>
	<u>4000</u>	<u>100</u>
	<u>6000</u>	<u>100</u>
	<u>8000 or more</u>	<u>100</u>
<u>5 to 8</u>	<u>2000</u>	<u>100</u>
	<u>4000</u>	<u>100</u>
	<u>6000</u>	<u>90</u>
	<u>8000 or more</u>	<u>90</u>
<u>9 to 12</u>	<u>2000</u>	<u>100</u>
	<u>4000</u>	<u>90</u>
	<u>6000</u>	<u>90</u>
	<u>8000 or more</u>	<u>80</u>
<u>13 to 16</u>	<u>2000</u>	<u>100</u>
	<u>4000</u>	<u>90</u>
	<u>6000</u>	<u>80</u>
	<u>8000 or more</u>	<u>80</u>
<u>17-24</u>	<u>2000</u>	<u>100</u>
	<u>4000</u>	<u>90</u>
	<u>6000</u>	<u>80</u>
	<u>8000 or more</u>	<u>70</u>
<u>25 and over</u>	<u>2000</u>	<u>100</u>
	<u>4000</u>	<u>90</u>
	<u>6000</u>	<u>70</u>
	<u>8000 or more</u>	<u>70</u>

(L) Request that Section 86 subcommittee initiates the subject – to revise Rule 86-300(2) as follows.

86-300 Branch circuits (see Appendix B)

(1) Electric vehicle supply equipment shall be supplied by a separate branch circuit that supplies no other loads except ventilation equipment intended for use with the electric vehicle supply equipment.

(2) Notwithstanding Subrule (1), electric vehicle supply equipment shall be permitted to be supplied from a branch circuit supplying another load(s), provided that [an Electric-Vehicle Energy Management System is installed in accordance with Subrule 8-106\(11\) or Subrule 8-106 \(12\).](#)

(3) For the purposes of Subrule (2), the calculated demand shall be determined in accordance with Section 8.

3585 GRAVELEY STREET. EP-2017-10194

Work Description:

Installation of Electric Vehicle Charging Systems and Electric Vehicle Energy Management System for the electric vehicle fleet application of 20 electric vehicles in this existing building. The existing facility capacity is 2000KVA and the 2016 December facility peak demand is 1392KW / 1435KVA. The proposed sum of charger maximum demands of 134KW which will be controlled by ChargePoint - Electric Vehicle Energy Management System. Scope of work includes installation of a 45 KVA transformer (@480V:208/120V - 125A continuous load @ 208/120V 3 phase); a 225A EV charger panel; 20X 40A EV charging stations (ChargePoint CPF25 Level 2 Charging Stations); 3 ChargePoint Gateway and a cell repeater. **Permit Terms:**

Note #1: A special permission has been granted to deviate from the requirements of Rule 8-104(5) & (6) of the 2015 CE Code based on the new requirements of "Electric Vehicle Energy Management System" and "Control of electric vehicle supply equipment loads" of Sections 8 and 86 of CANADIAN ELECTRICAL CODE, PART I of the Consolidated Memorandum of Revisions to the 2015 (23rd) edition.

Note #2: The ChargePoint Gateway is owned and maintained by ChargePoint must have an annual permit in conformance with the Vancouver Electrical B-law No.5563)

Note #3: The Electric Vehicle Energy Management System must not adversely affect operation of the life safety systems, essential electrical system and emergency electrical power supply system, where applicable.

Note #4: The Electric Vehicle Energy Management System must meet the fundamental principles of protection for safety mandated by the CEC; and must not cause the load of the branch circuit, feeder or service to exceed requirements of CEC Rule 8-104(5) & (6).

ELECTRIC VEHICLE ENERGY MANAGEMENT SYSTEMS

This bulletin provides guidance on the installation of electric vehicle energy management systems as pertaining to the 2015 BC Electrical Code Regulation. The requirements of local municipal authorities having jurisdiction may vary. Owners, Designers, and Installers should consult with local authorities having jurisdiction, prior to undertaking work, to determine their requirements.

Date of Issue: Month XX, 20XX**No: IB-XX YYYY-XX****Topic: This bulletin provides guidance regarding electric vehicle energy management systems, their features, and safety considerations,**

Explanation: Electric vehicle energy management systems (EVEMS) are defined as a means of controlling electric vehicle supply equipment loads comprised of any of the following: a monitor(s), communications equipment, a controller(s), a timer(s) and other applicable device(s). EVEMS are rapidly becoming available for use in British Columbia. These EVEMS are available for all types of occupancies and locations, and for both new and existing installations. The current edition of the BC Electrical Code Regulation 2015, Section 86 Electrical Vehicle Charging Systems recognizes load management systems at a branch circuit level; this section does not extend the load management systems to include distribution equipment, feeder conductors or services.

A variance may be considered to allow the use of an EVEMS to limit the demand on distribution equipment, services, or feeders.

Rationale: The BC Electrical Code Regulation, Section 8, Circuit Loading and Demand Factors, and Section 86, Electric Vehicle Charging Systems do not permit the installation of any electrical equipment or systems such as EVEMS if the calculated load or demonstrated load exceeds the rating of the distribution equipment, feeder conductors or services. Electric vehicle charging equipment must be calculated at 100% load based upon the nameplate rating of the equipment. Provisions for switching of loads have been identified in several rules such as 8-106(3), (5), (9) and (10). There are no requirements or recognition of how to control the switching of energy management systems.

The control of electric vehicle supply equipment loads is the process of connecting, disconnecting, increasing, or reducing electric power to electric vehicle supply equipment loads .

The 2018 Edition of the Canadian Electrical Code recognizes technology advancements for EVEMS. The impact of these revisions has not been determined, and the 2018 Canadian Electrical Code has not been adopted into regulation. In the interim, Technical Safety BC, and by local government authorities having jurisdiction where applicable, will consider applications for variance to Section 8 and 86 for any installation of an EVEMS to limit the demand on services and feeders.

Some EVEMS allows an administrator to manage, monitor, and control loads. These systems will require the administrator to play an important role in the safe management of the demand loads on the service, feeders, and branch circuits. When the necessity for an administrator is identified in the plans and specifications, an operating permit will be required for all occupancies.

BC Safety Authority is now Technical Safety BC.

While we have changed our name, we remain committed to our vision of *Safe technical systems. Everywhere.*

www.technicalsaftybc.ca | toll-free 1 866 566 7233

Residential installations are considered non-continuous loads and the electrical equipment sized for use in these types of occupancies may not be capable of safely operating an EVEMS. The installation of an EVEMS may cause the service or feeders to become overloaded as the loads being managed may be considered continuous, and no longer meet the requirements of rules 4-004(23), 8-200(3) and 8-202(2). In this case, the equipment affected by the additional loads will need to be upgraded.

All plans and specifications, load calculations, and variance applications shall be submitted to the appropriate Authority Having Jurisdiction (AHJ). See Information Bulletin, 2016-05.

https://www.technicalsaftybc.ca/sites/default/files/section_2_-_general_rules_ib-el_2016-05.pdf

Utility equipment is not regulated by the BC Electrical Code but is effected by the installation of these systems as the average overall demand on their infrastructure may be increased. Conditions for a variance will require that the utility be consulted and notified of all EVEMS installations when the service could be overloaded with the failure or removal of the EVEMS.

Installation Permits: Variance applications and confirmation of utility acceptance shall be submitted with the plans and specifications.

Plans and specifications shall include load calculations in accordance with the BC Electrical Code. All loads being managed by the EVEMS shall be identified and included in load calculations.

It is the permit holder's responsibility to demonstrate the installation is compliant with the variance.

Operating Permits: The installation of electric vehicle charging equipment and EVEMS may be installed under an operating permit provided the total load being connected does not exceed the requirements of the Directive: Electrical Operating Permit Requirements. The connected load shall be determined by the nameplate markings on the equipment.

A copy of the accepted variance and associated documentation, plans and specifications, and utility acceptance, must be maintained at the facility; the location of this documentation must be recorded in the log book. The installation must be accepted in writing by the FSR named on the operating permit.

Variance Process:

A variance will be required when the application of rules 8-106 (11) and (12), rule 8-500 and or rule 86-300 (Annex A) are used when determining the calculated or demonstrated loads.

Applications for variance, that do not clearly identify the specific rule(s) being requested for variance, and are not supported by rationale and clear descriptions and explanations of the system design and operation will not be accepted. *[enter sentence referencing variance application special form if approved by committee]*

Provincial Safety Manager - XXXX

BC Safety Authority is now Technical Safety BC.

While we have changed our name, we remain committed to our vision of *Safe technical systems. Everywhere.*

www.technicalsaftybc.ca | toll-free 1 866 566 7233

References:

Safety Standards Act

Electrical Safety Regulation

Safety Standards Act Repeal and Transitional Provisions Regulations

Safety Standards Act:

Variance — means a document without precedential value issued, for an individual circumstance on a single occasion, by a safety officer or safety manager allowing

(a) a deviation from the application of a regulation under this Act, or

(b) a use, other than the standard use, of a regulated product if the proposed use is not specifically prohibited under this Act.

Variations

32 (1) A safety officer may, if requested by any person, issue, in writing, a variance to the person varying the application of a provision of the regulations with respect to a regulated product or regulated work.

(2) A variance may

(a) be made subject to terms and conditions specified by the safety officer, and

(b) continue for a specified period of time.

(3) If the person who holds a variance complies with the terms and conditions of the variance, the person must be considered to be in compliance with the regulation that it varies.

(4) If a person applies for a variance and a safety officer refuses to issue it, or issues it with terms or conditions attached to it that are not requested or agreed to by the applicant, the safety officer who deals with the application must inform the applicant and, if the applicant requests written notice, give the applicant written notice of that decision.

(5) A written notice under subsection (4) must state the reasons for the decision and that the applicant has the right to make a written request for a review by a safety manager.

(6) A decision of a safety manager on a review of a decision under subsection (4) is not appealable to the appeal board.

BC Safety Authority is now Technical Safety BC.

While we have changed our name, we remain committed to our vision of *Safe technical systems. Everywhere.*

www.technicalsaftybc.ca | toll-free 1 866 566 7233

ANNEX A

For the purposes of simplicity, the new rules affected by this technology are listed. All variance applications shall include the following definitions and rules as supporting documentation for consideration. A reference to this bulletin including revision # will satisfy this obligation.

Definitions: (for the purpose of this bulletin and any associated variances)

Administrator — the person responsible for operating the electric vehicle energy management system (or his or her designee)

Note: *The term “administrator” is used in this Bulletin to denote the person having the ability to manage and control the power to the equipment and charged with responsibilities specified in rule 8-500. The administrator may (and usually does) delegate these responsibilities to appropriately qualified individuals.*

Fail-Safe Condition: A safe condition in the event of a breakdown or malfunction of the EVEMS.

[New Special terminology \(24th Edition of the CEC\)](#)

[Control of electric vehicle supply equipment loads – the process of connecting, disconnecting, increasing, or reducing electric power to electric vehicle supply equipment loads .](#)

[Electric Vehicle Energy Management System – a means of controlling electric vehicle supply equipment loads comprised of any of the following: a monitor\(s\), communications equipment, a controller\(s\), a timer\(s\) and other applicable device\(s\).](#)

[Add new Subrules 8-106\(11\) and \(12\) to read:](#)

[8-106 Use of demand factors \(see Appendix B\)](#)

[\(11\) Where electric vehicle supply equipment loads are controlled by an Electric Vehicle Energy Management System, the demand load for the electric vehicle supply equipment shall be equal to the maximum load allowed by the Electric Vehicle Energy Management System.](#)

[\(12\) For the purposes of Rules 8-200\(1\)\(a\)\(vi\), 8-202\(3\)\(d\), 8-204\(1\)\(d\), 8-206\(1\)\(d\), 8-208\(1\)\(d\) and 8-210\(b\), where an Electric Vehicle Energy Management System described in 8-106\(11\), monitors the consumer's service and feeders and controls the electric vehicle supply equipment loads in accordance with Rule 8-500, the demand load for the electric vehicle supply equipment is not required to be considered in determination of the calculated load.](#)

[Electric vehicle energy management systems](#)

[8-500 Electric Vehicle Energy Management Systems](#)

BC Safety Authority is now Technical Safety BC.

While we have changed our name, we remain committed to our vision of *Safe technical systems. Everywhere.*

www.technicalsaftybc.ca | toll-free 1 866 566 7233

(1) Electric vehicle energy management systems shall be permitted to monitor electrical loads and to control electric vehicle supply equipment loads.

(2) An electric vehicle energy management system shall not cause the load of a branch circuit, feeder, or service to exceed requirements of Rules 8-104(5) or 8-104(6).

(3) An electric vehicle energy management system shall be permitted to control electrical power through the use of a remote means.

86-300 Branch circuits (see Appendix B)

(1) Electric vehicle supply equipment shall be supplied by a separate branch circuit that supplies no other loads except ventilation equipment intended for use with the electric vehicle supply equipment.

(2) Notwithstanding Subrule (1), electric vehicle supply equipment shall be permitted to be supplied from a branch circuit supplying another load(s), provided that [an Electric-Vehicle Energy Management System is installed in accordance with Subrule 8-106\(11\) or Subrule 8-106 \(12\).](#)

(3) For the purposes of Subrule (2), the calculated demand shall be determined in accordance with Section 8.

BC Safety Authority is now Technical Safety BC.
While we have changed our name, we remain committed to our vision of *Safe technical systems. Everywhere.*

www.technicalsaftybc.ca | toll-free 1 866 566 7233



Request for Variance

Payment Card Industry Data Security Standards prevent the use of credit card information sent through email or fax. A Client Service Representative will contact you within three business days to complete any payment process required.

Note: The information on this form is collected to administer the provisions of the Safety Standards Act and section 26 of the Freedom of Information and Protection of Privacy Act. If you have questions about the collection, use, or disclosure of this information, contact the Records, Information & Privacy Analyst at 1-866-566-7233.

This request for variance must only be completed and signed by the person in charge of the regulated work where the variance is being requested. It is an offence to knowingly provide false information on this document.

If this Request for Variance is refused or if a variance is issued to you with terms and conditions that you do not agree with, you may request in writing, that this decision be reviewed by a Safety Manager in accordance with section 49 of the Safety Standards Act.

Applicant:

Name: Royce Bernard Title: Electrical Engineer
Qualification and I.D. # (If applicable) (e.g., TQ/CQ/P.Eng./AscT/Other -- specify): P.Eng. License: 161157
Telephone: (604) 365 - 0634 Email address (if applicable): Royce.Bernard@AESEngr.com
Name of Employer: AES Engineering Ltd.
Address of Employer: 1330 Granville Street
City: Vancouver Province: British Columbia Postal Code: V6Z 1M7
Telephone: (604) 569 - 5600 Email address (if applicable): n/a

Asset Holder / Equipment Owner / Location of Variance Information:

Name of Employer: City of New Westminster
Address of Employer: 905 First Street
City: New Westminster Province: British Columbia Postal Code: V3L 2J1
Telephone: (604) 515 - 3752 Email address (if applicable): mnash@newwestcity.ca
Single Location: [X] Address: Queen's Park Arena Parking Lot, New Westminster, BC
Multiple Locations: [] (Attach list for multiple locations)

Permit/EVEMS/EVSE Information:

This Request for Variance is being made for regulated work performed under the following permit:

Installation Permit #: EL-646545-2018 Reference # (if application is for plan acceptance):
New Installation: Yes [X] No []; Addition or alteration of existing installation: Yes [X] No [].

EVSE: Manufacturer: IBX; Model: VariableGrid; Rating: 208/240 V, 1 Ph; 32 A;
Qty: 4; Fail-Safe Condition: 0 Amps per charging station.

EVEMS: Approved by Certification Body for their intended use;

C22.2 NO. 280-13 - Electric vehicle supply equipment, Tri-national standard, with UL 2594 and NMX-J-677-ANCE-2013; Yes [] No [X]

SPE-1000, Model Code for the Field Evaluation of Electrical Equipment; Yes [X] No []

C22.2 NO. 0.8-12 (R2016) - Safety functions incorporating electronic technology; Yes [] No [X]

If no, provide details as to how the system will be managed and satisfy the requirements of Rule 8-500 in Annex A of Information Bulletin.

If no, provide documentation as per Information Bulletin;

Technical Safety BC is working towards going paperless! Participate by signing up for email correspondence.

EVEMS: Manufacturer: IBX; Model: VariableGrid Server; Rating: 208 V, 1 Ph; 40 A;
 Qty: 1; Load under management: 40 A / unit; Total Load under management: 40 A.
 Type of control: Communications equipment
 The control is supplied by Manufacturer of EVSE:Yes No ; If no, supplied by third party provider? Yes No ;
 If not supplied by manufacturer provide documentation as per information bulletin;
 Capable of managing and controlling loads affecting: service..... Yes No ;
 feeders Yes No ;
 branch circuits Yes No .
 Capable of managing and controlling power production equipment (bi-directional power transfer)? Yes No ;
 Does the EVEMS require an 'Administrator' as defined? Yes No ;
 If yes, provide Operating Permit application or confirm Permit number in this application.

Variance Information:

This request for variance is being made in relation to the following type of regulated product (choose one):

- Electric Vehicle Charging Equipment Electric Vehicle Energy Management System Both

Specify the code rules to which the variance applies: (select all that apply)

- 2-024, Use of approved equipment
- 8-106, Circuit Loading and the use of Demand Factors 8-106 (11), (12), EVEMS, see bulletin 8-500, EVEMS, see bulletin
- 8-200, Single Dwellings 8-202, Apartment, etc. 8-204, Schools 8-206, Hospitals 8-208, Hotels, Motels, etc.
- 8-210, Other types of occupancies (industrial, commercial, theatre, street lighting, parkades, repair facilities): _____
-
- 86-300, Electric vehicle supply equipment, Branch Circuits

Other Rules and considerations: (List and explain)

The utility has been made aware of this installation and the calculated average monthly demand has been communicated to the utility.

Rule 2-014: Plans and specifications of the equipment and the electrical system including load calculations have been attached to this variance application Yes No

Rule 8-106: Load Calculation is attached for review and acceptance..... Yes No

Identify the safety objectives, by section as specified above, of the applicable regulations and codes:

The EVSE is intrinsically safe, in accordance with testing and certification requirements; it is only the EVEMS that has not been tested and certified in accordance with a recognized standard. In absence of a recognized standard, manufacturers implement various test procedures, including the use of electric vehicle (EV) simulators and/or connection of EV's. Scenarios, such as loss of communications and software failure are tested to ensure appropriate operation.

Specify the alternative means by which it is proposed to meet the safety objectives:

The alternative means are specified under provisions of CSA C22.1-18, which permits the use of EVEMS. It is the intent to utilize this energy management system for this project under Rule 2-030 (provision for special permission). EVSE with energy management capabilities ensures the demand load for the EVSE will not exceed the maximum load allowed by the system. This Rule was adopted unanimously by all stakeholders (including regulators of BC) on Part I Committee.

Provide any other objectives, alternatives, and evidence that the alternative will meet the objectives identified:

Not Applicable.

I have read the information bulletin on electric vehicle energy management systems and the equipment and system for which this variance is being applied for meets or exceeds the requirements listed in the bulletin.

I certify that I am the person in charge of the work described in this request for variance and am authorized to make this request on behalf of my employer. I agree to indemnify and save harmless the British Columbia Safety Authority (the Authority) and the staff of the said Authority against all claims, liabilities, judgments, costs and expenses of whatsoever kind which may accrue against the said Authority and staff in connection with any work under the authority of this request for variance. If the variance is granted by this application, I agree to the terms and conditions set forth in this document and any other conditions set by the provincial safety manager, local safety manager, or safety officer.

Checking this box and submitting this form to Technical Safety BC via email constitutes your authorization. This has the same effect as submitting a handwritten signature.

Signature:  Date: March 6, 2018



Mar. 6, 2018

Technical Safety BC Office Use Only

Approved

Rejected

Reviewed By: _____

Title: _____

Phone: _____

Email: _____

Comments:

Terms and Conditions:

I agree to the following terms and conditions for all that apply to the systems being installed:

The EVEMS shall not cause the load of any regulated equipment to exceed the rating on the equipment;

The EVEMS shall be continuously operational when charging is occurring;

In the event the EVEMS becomes inoperable, the resultant connected load capable of operation without EVEMS is considered continuous and calculated at a demand of 100%;

The EVEMS shall disconnect the EVSE from the source of supply in the case of under voltage, loss of power, or if there is a loss of communications between the EVEMS and the EVSE, when it is evident automatic restarting, or the lack of communications is liable to create a hazard;

The EVEMS by means of both control and management of loads will maintain safe operating conditions on the service, feeder and branch circuit. A fail-safe monitoring system is included in the system. Failure of the system including communications will result in the EVSE to become disabled. Under no circumstances shall the EVEMS re-direct power from any required ventilation, emergency services or essential loads.

An EVEMS that has the ability to manage and control an electric vehicle used as an electric production source shall not provide power to loads in excess of the output rating of the production source equipment (i.e. No manual load-shedding, EVEMS shall have control or provide dedicated panel for loads);

The asset holder or equipment owner, administrator, and operators will be provided with the necessary training to operate the system in a safe manner. Confirmation of this training will be provided through the permit holder, and if different from this variance, with the inspection request for energization of the equipment or with the declaration into the log book; and

The terms and conditions applied in this variance shall also be considered set as terms and conditions for any operating permit(s) associated with this variance.

APPENDIX F: STRATA ISSUES

1.0 KEY CONSIDERATIONS FOR STRATA BYLAWS AND/OR RULES

The following information includes a summary of provisions in the British Columbia *Strata Property Act* relating to the installation of EVSE, general recommendations, and issues to be addressed when preparing bylaw language. It should not be treated as case specific legal advice, and engagement of legal advice is recommended when preparing bylaw amendments.

1.1 A Summary of Parking Under the *Strata Property Act*

The possible locations of EVSE will depend on how the parking stalls are designated, and every strata plan is different. A parking stall could be: common property, common property which is subject to a lease; limited common property; or part of a strata lot. The following are documents that should be reviewed in order to determine how the parking is held:

- Common Property Index obtained from the Land Title Office. This is a search which shows all charges on title to the common property of the strata corporation, and includes easements, covenants, and some leases. If the owner developer entered into a lease of the parking stalls, it may (but may not) be shown on the common property search.
- Developer's disclosure statement, a copy of which can be obtained from the Superintendent of Real Estate. This will indicate whether the parking stalls are subject to a lease entered into by the owner developer.
- Strata Property General Index obtained from the Land Title Office. This will identify all registrations in the Land Title Office, and will show whether limited common property has been designated by a 3/4 vote resolution.
- Bylaws of the strata corporation obtained from the Land Title Office. Section 120 of the *Strata Property Act* provides that the bylaws of a strata corporation are the *Strata Property Act* Standard Bylaws, except to the extent that different bylaws are filed in the Land Title Office. All strata corporations have different bylaws, and it is critical to obtain the registered bylaws from the Land Title Office.
- Rules of the strata corporation in accordance with Section 125 of the *Strata Property Act*.

1.2 How Parking in a Strata Plan May be Held

Whether EVSE may be installed in a parking stall depends on how the parking stall is held, and who is proposing to use the parking stall and the EVSE. This section discusses the different ways that parking may be held.

Strata Lot

Although rare, there are some strata corporations in British Columbia that show parking stalls as a separate strata lot on the strata plan. If the strata plan shows a parking stall as a strata lot, a title search can be obtained from the Land Title Office in order to determine the name of the registered owner.

A parking stall which is a strata lot cannot be used by any party other than the registered owner, except with consent from that registered owner. The registered owner would have the ability to install EVSE upon receipt of approval from the strata council (see below). However, the owner of a different strata lot, or an occupant or tenant would not have any right to use the parking stall.

Common Property

Common property is defined as follows under the *Strata Property Act*:

- (a) *that part of the land and buildings shown on a strata plan that is not part of a strata lot, and*
- (b) *pipes, wires, cables, chutes, ducts and other facilities for the passage or provision of water, sewage, drainage, gas, oil, electricity, telephone, radio, television, garbage, heating and cooling systems, or other similar services, if they are located*
 - (i) *within a floor, wall or ceiling that forms a boundary*
 - (A) *between a strata lot and another strata lot,*
 - (B) *between a strata lot and the common property, or*
 - (C) *between a strata lot or common property and another parcel of land, or*
 - (ii) *wholly or partially within a strata lot, if they are capable of being and intended to be used in connection with the enjoyment of another strata lot or the common property;*

Common property constitutes any part of the strata plan which is not shown on the strata plan as a strata lot. When reviewing the strata plan, one must look at the legend on the strata plan to determine what the various symbols mean. Sometimes common property is shown as a “c” with a circle around it (©). Alternatively, it could be shown with a different symbol, or it could have no symbol at all. If it does not have a symbol, and is not part of a strata lot, by definition it constitutes common property.

(i) Grant Under Condominium Act

The *Condominium Act* is the predecessor legislation to the *Strata Property Act*. Under Section 117(f) of the *Condominium Act*, the strata corporation had the right to grant exclusive use or special privileges for common property. Section 117(f) of the *Condominium Act* provided that the strata corporation may:

(f) grant an owner the right to exclusive use and enjoyment of common property, or special privileges for them, the grant to be determinable on reasonable notice, unless the strata corporation by unanimous resolution otherwise resolves;

Strata Property Act Regulation 17.7 addresses how a grant of exclusive use or special privileges under the Condominium Act should be dealt with. It provides that:

Despite section 76 (2) of the Act, a right, permission or privilege granted, before the coming into force of this section, under section 117 (f) of the Condominium Act or a similar bylaw under which the strata corporation gives an owner permission to exclusively use or enjoy, or a special privilege in relation to, common property that is not designated as limited common property under section 53 of the Condominium Act continues to be enforceable in accordance with its terms, but may be renewed only as permitted by section 76 of the Act.

There are some strata corporations in British Columbia in which owners or tenants may have the right to use a parking stall based on a grant under the *Condominium Act*.

(ii) Lease by Owner Developer

Common property parking stalls may be subject to a lease entered into by the owner developer prior to the deposit of the strata plan. In those circumstances, the typical process of the owner developer is to enter into a written lease of the common property with a third party parking company. Then, at the time that the strata lots are sold to purchasers of strata lots, each parking stall is subleased by the parking company to the purchasers. If a parking stall is subject to a lease, the use of the parking stall is subject to the terms of the lease or a sub-lease, and the owner and the strata corporation are obligated to comply with the terms of the lease or sub-lease.

(iii) No Lease by Owner Developer

If common property is not subject to a lease entered into by the owner developer, it may be assigned by the strata corporation to owners or tenants in accordance with the terms of Section 76 of the *Strata Property Act*, which provides as follows:

(1) Subject to section 71, the strata corporation may give an owner or tenant permission to exclusively use, or a special privilege in relation to, common assets or common property that is not designated as limited common property.

(2) A permission or privilege under subsection (1) may be given for a period of not more than one year, and may be made subject to conditions.

(3) The strata corporation may renew the permission or privilege and on renewal may change the period or conditions.

(4) The permission or privilege given under subsection (1) may be cancelled by the strata corporation giving the owner or tenant reasonable notice of the cancellation.

(iv) Visitor Parking

A common property parking stall may be designated by the strata corporation as visitor parking and governed by the bylaws or rules of the strata corporation.

Limited Common Property

Limited Common Property is defined as follows in the *Strata Property Act*:

Limited common property means common property designated for the exclusive use of the owners of one or more strata lots;

Limited common property may be designated on the strata plan or by a 3/4 vote. Section 73 of the *Strata Property Act* provides as follows:

Common property may be designated as limited common property

(a) by the owner developer

(i) by a designation on the strata plan when it is deposited in the land title office, or

(ii) by a plan amendment under section 258,

(b) by an amendment to the strata plan under section 257, or

(c) by a resolution passed at an annual or special general meeting under section 74.

A person may review the registered strata plan in order to determine whether a parking stall is designated as limited common property. When reviewing a strata plan, one must review the legend to determine the meaning of the various symbols. Sometimes, limited common property is indicated as a number with a circle around it. The number refers to the number of the strata lot to which exclusive use has been designated.

If the parking stall is not shown as limited common property on the strata plan, it may still have been designated as limited common property under Section 74 of the *Strata Property Act*, which provides as follows:

- (1) *Common property may be designated as limited common property by a resolution passed by a 3/4 vote at an annual or special general meeting.*
- (2) *A resolution passed under subsection (1) must be filed in the land title office with a sketch plan that*
 - (a) *satisfies the registrar,*
 - (b) *defines the areas of limited common property, and*
 - (c) *specifies each strata lot whose owners are entitled to the exclusive use of the limited common property.*
- (3) *A resolution passed under subsection (1) does not have effect until it is filed in the land title office.*
- (4) *The designation of limited common property by a resolution under this section does not require an amendment to the strata plan.*

In order to determine whether a parking stall has been designated as limited common property by a 3/4 vote, a person must review the Strata Property General Index. If it indicates that a resolution has been filed at the Land Title Office to designate limited common property, it will also refer to the Land Title Office document number which applies to that designation. By pulling a copy of the resolution and the sketch plan attached to that resolution, a person can determine those areas which have been designated as limited common property.

1.3 Alterations to Parking Stalls

Under the bylaws and rules of the strata corporation, it is likely that an owner, occupant or tenant who wishes to install EVSE will require approval from the strata council before EVSE can be installed. All strata corporations have different bylaws. For the purposes of this guide, we have referred to the *Strata Property Act* Standard Bylaws. However, it is critical to pull bylaws from the Land Title Office in order to refer to the bylaws which are specific to that strata corporation.

Common Property and Limited Common Property

Standard Bylaw 6 provides that an owner must obtain written approval of the strata corporation before making an alteration to common property. Standard Bylaw 6 provides as follows:

- (1) *An owner must obtain the written approval of the strata corporation before making an alteration to common property, including limited common property, or common assets.*
- (2) *The strata corporation may require as a condition of its approval that the owner agree, in writing, to take responsibility for any expenses relating to the alteration.*

Although the strata council has a duty under Section 31(a) of the *Strata Property Act* to act honestly and in good faith with a view to the best interest of the strata corporation, there is nothing in the Standard Bylaw which requires the strata corporation not to unreasonably withhold its approval for alterations to common property. This is one of the challenges in enabling EV use in existing strata corporations. Strata councils may refuse to grant approval for alteration of a common property parking stall to install EVSE for all or some of the following reasons:

- a lack of understanding or interest; or
- concern that the EVSE may damage the common property; or
- concern that the use of EVSE by an owner may result in the owner using a larger share of the strata corporation's electricity without a corresponding obligation to pay a greater portion of costs.

While the Standard Bylaw does not require a strata corporation to approve alterations to common property, strata council members are required to consider requests to approve alterations honestly and in good faith to maintain their protection from person liability under the *Strata Property Act* [Ref. s.22(1)].

The information in this report may assist with overcoming some of these issues.

Section 71 of the *Strata Property Act* provides as follows:

Subject to the regulations, the strata corporation must not make a significant change in the use or appearance of common property or land that is a common asset unless

- (a) the change is approved by a resolution passed by a 3/4 vote at an annual or special general meeting, or*
- (b) there are reasonable grounds to believe that immediate change is necessary to ensure safety or prevent significant loss or damage.*

It is likely that the first installation of EVSE in a common property parking stall constitutes a significant change in the use or appearance of common property, and requires a resolution approved by a 3/4 vote at a general meeting of the strata corporation.

Strata Lot

Bylaw 5 of the *Strata Property Act* Standard Bylaws prevents an owner from altering a strata lot, except with written approval from the strata corporation. Therefore, if a parking stall constitutes a strata lot, the owner may not install EVSE in it except with written consent from the strata corporation. Standard Bylaw 5 provides as follows:

- (1) An owner must obtain the written approval of the strata corporation before making an alteration to a strata lot that involves any of the following:*
 - (a) the structure of a building;*
 - (b) the exterior of a building;*
 - (c) chimneys, stairs, balconies or other things attached to the exterior of a building;*
 - (d) doors, windows or skylights on the exterior of a building, or that front on the common property;*
 - (e) fences, railings or similar structures that enclose a patio, balcony or yard;*
 - (f) common property located within the boundaries of a strata lot;*
 - (g) those parts of the strata lot which the strata corporation must insure under section 149 of the Act.*

- (2) *The strata corporation must not unreasonably withhold its approval under subsection (1), but may require as a condition of its approval that the owner agree, in writing, to take responsibility for any expenses relating to the alteration.*
- (3) *This section does not apply to a strata lot in a bare land strata plan.*

1.4 Repair and Maintenance

Under the *Strata Property Act*, a strata corporation is responsible for managing and maintaining the common property. Section 3 of the *Strata Property Act* provides as follows:

- (1) *An owner, tenant, occupant or visitor must not use a strata lot, the common property or common assets in a way that*
- (a) causes a nuisance or hazard to another person,*
 - (b) causes unreasonable noise,*
 - (c) unreasonably interferes with the rights of other persons to use and enjoy the common property, common assets or another strata lot,*
 - (d) is illegal, or*
 - (e) is contrary to a purpose for which the strata lot or common property is intended as shown expressly or by necessary implication on or by the strata plan.*
- (2) *An owner, tenant, occupant or visitor must not cause damage, other than reasonable wear and tear, to the common property, common assets or those parts of a strata lot which the strata corporation must repair and maintain under these bylaws or insure under section 149 of the Act.*

Standard Bylaw 8 provides that a strata corporation must repair and maintain common property that has not been designated as limited common property. In addition, Section 72 of the *Strata Property Act* provides that a strata corporation must repair and maintain common property.

If the strata corporation gives approval to an owner, occupant, or tenant to install EVSE on common property or limited common property, and if the strata corporation intends that the owner, occupant, or tenant will be the party responsible for repairing and maintaining the EVSE, the strata corporation should enter into a comprehensive Alteration and Indemnity Agreement in order to ensure that the owner, occupant, or tenant is responsible for future costs related to the repair and maintenance.

1.5 Swapping Parking Stalls

There may be certain parking stalls which are more suited to EVSE. However, the ability of an owner, occupant, tenant, or strata corporation to install EVSE depends on how the parking stall is held. The ability to swap or change users of a parking stall may be difficult, or impossible depending on whether the parking stall is common property, limited common property, or a strata lot.

Swapping parking stalls is not recommended as it does not assist in the development of infrastructure needed to support EV adoption, and is not applicable to properties that have the required electrical installation for 100% of stalls.

Common Property

If the parking stall is common property, it may be held in one of the following ways:

- (i) pursuant to a lease entered into by the developer; or
- (ii) pursuant to a grant of exclusive use or special privilege under the *Condominium Act*, which has been preserved under Regulation 17.7 of the *Strata Property Act*; or

- (iii) pursuant to a grant of exclusive use under Section 76 of the *Strata Property Act*; or
- (iv) as visitor parking.

If the common property parking stall is held by an owner pursuant to a lease and sub-lease originally entered into by the developer and assigned to the first purchaser, the ability of an owner or strata corporation to swap the parking stall with another will depend on the provisions of the lease and the sub-lease. Some leases specifically contemplate that owners may trade stalls by agreement with each other and by notice to or consent from the strata corporation. Others do not contain such a provision. This can limit the ability of parties to swap stalls in order to enable the installation of EVSE in an appropriate stall.

If a common property parking stall is assigned by the strata corporation in accordance with Section 76 of the *Strata Property Act*, the strata corporation has the ability to re-assign it. Designations under Section 76 may be given for a period of not more than one year, and may be cancelled by giving the owner or tenant reasonable notice of the cancellation. However, in making a decision to swap a common property parking stall, the strata corporation should be aware of Section 164 of the *Strata Property Act*, which provides as follows:

- (1) *On application of an owner or tenant, the Supreme Court may make any interim or final order it considers necessary to prevent or remedy a significantly unfair*
 - (a) *action or threatened action by, or decision of, the strata corporation, including the council, in relation to the owner or tenant, or*
 - (b) *exercise of voting rights by a person who holds 50% or more of the votes, including proxies, at an annual or special general meeting.*
- (2) *For the purposes of subsection (1), the court may*
 - (a) *direct or prohibit an act of the strata corporation, the council, or the person who holds 50% or more of the votes,*
 - (b) *vary a transaction or resolution, and*
 - (c) *regulate the conduct of the strata corporation's future affairs.*

If a right to a common property parking stall was granted under the *Condominium Act*, the right to continue using the parking stall would be dependent on the terms of the strata corporation resolution granting the right. This would require a review of strata corporation records.

If a parking stall is designated as visitor parking, the strata corporation should consider whether owners, occupants, or tenants will use the EVSE, and whether changes to the bylaws or rules are required. The use of a visitor parking stall by owners, occupants or tenants would likely require approval by a 3/4 vote under Section 71 of the *Strata Property Act* (see above).

Limited Common Property

The ability to swap a limited common property parking stall depends on how it was designated. If it was designated on the strata plan, the only way to remove the designation is to amend the strata plan under Section 257 of the *Strata Property Act*, which provides as follows:

To amend a strata plan to designate limited common property, or to amend a strata plan to remove a designation of limited common property made by the owner developer at the time the strata plan was deposited or by amendment of the strata plan, the strata plan must be amended as follows:

- (a) *a resolution approving the amendment must be passed by a unanimous vote at an annual or special general meeting;*

- (b) *an application to amend the strata plan must be made to the registrar accompanied by*
 - (i) *a reference or explanatory plan, whichever the registrar requires, that*
 - (A) *shows the amendment, and*
 - (B) *is in a form required under the Land Title Act for a reference or explanatory plan, and*
 - (ii) *a Certificate of Strata Corporation in the prescribed form stating that the resolution referred to in paragraph (a) has been passed and that the reference or explanatory plan conforms to the resolution.*

This is costly, because it requires a reference or explanatory plan to be prepared by a land surveyor. In addition, the amendment is very difficult to obtain because it requires a unanimous vote at a general meeting. Unanimous resolution is defined as follows under the *Strata Property Act*:

a vote in favour of a resolution by all the votes of all the eligible voters;

In other words, it does not just require a resolution of all of the owners in attendance at a general meeting, it requires a resolution of all eligible voters. This is very difficult to achieve.

Strata Lot

If a parking stall is a strata lot, the strata corporation has no authority to swap it. It is the property of the registered owner.

1.6 Should a Strata Corporation be Considered a Public Utility Under the *Utilities Commission Act*?

There has been significant uncertainty in British Columbia over whether condo corporations are permitted to bill their owners for energy costs the condo corporations incur from EV charging because of a concern that doing so would make them a "public utility" and trigger regulation by the BC Utilities Commission.

Under the *Utilities Commission Act*, a public utility is defined to include a "person...who owns or operates in British Columbia, equipment or facilities for...the production, generation, storage, transmission, sale, delivery or provision of electricity...for the production of light, heat, cold or power to or for the public or a corporation for compensation" (s.1).

There are two interpretations of this provision. The first, more conservative interpretation is that charging condo residents for electricity delivered for EV charging falls within the definition of "public utility" under the *Utilities Commission Act*. This would mean that any Strata Corporation hoping to pass on these costs would be subject to BCUC regulation and would likely need to apply to the BCUC for permission to do things including setting rates. It is unlikely that most or even any strata corporations would take this step, meaning that taking this conservative approach would be highly inefficient and likely restrain investments in EV charging by Strata Corporations.

A second, less conservative interpretation, is that strata owners are neither "the public" nor "a corporation" vis-à-vis their Strata Corporations, and that they are therefore not caught by the definition of public utility, which is premised upon the electricity being sold, delivered or provided "to the public" or "to a corporation". In addition, charging for energy delivered to strata owners is different than charging "the public", since strata owners have the ability to vote on by-laws at their strata and are legal owners of their units. The less conservative argument is also supported by the recent decision of the BC provincial government to amend the *Strata Property Act* to expressly allow Strata Corporations to charge variable user fees (see Section 1.9) with the express purpose that "A consumption-based rate may be charged to users to recover expenses as long as it is reasonable and in a strata bylaw or rule. For example:

electricity usage for strata residents charging their electric vehicles."¹ A similar regime is also already in place for gas fireplaces, where it is common for Strata Corporations to charge based on gas supply costs, if such a process is set out in a by-law.²

It is not clear which of the two interpretations of the Utilities Commission Act the BCUC will adopt, but it has been asked to consider this issue by a number of parties in the currently ongoing Inquiry into the Regulation of Electric Vehicle Charging Service.³ This is, therefore, an issue to watch closely for ongoing developments.

1.7 Summary of Expenses Under the *Strata Property Act*

Common Expenses

Common Expenses are defined as follows under the Strata Property Act:

- (a) relating to the common property and common assets of the strata corporation, or
- (b) required to meet any other purpose or obligation of the strata corporation;

Section 92 of the *Strata Property Act* makes the strata corporation responsible to pay common expenses. It provides as follows:

To meet its expenses the strata corporation must establish, and the owners must contribute, by means of strata fees, to

- (a) an operating fund for common expenses that
 - (i) usually occur either once a year or more often than once a year, or
 - (ii) are necessary to obtain a depreciation report under section 94, and
- (b) a contingency reserve fund for common expenses that usually occur less often than once a year or that do not usually occur.

The expense of electricity consumption is the kind of expense that occurs once a year or more often than once a year. Alternatively, the cost to install EVSE may be a cost that occurs less often than once a year or that does not usually occur.

Expenses that occur less often than once a year or that do not usually occur can be raised under Section 108 of the *Strata Property Act*, which provides as follows:

- (1) *The strata corporation may raise money from the owners by means of a special levy.*
- (2) *The strata corporation must calculate each strata lot's share of a special levy*
 - (a) *in accordance with section 99, 100 or 195, in which case the levy must be approved by a resolution passed by a 3/4 vote at an annual or special general meeting, or*
 - (b) *in another way that establishes a fair division of expenses for that particular levy, in which case the levy must be approved by a resolution passed by a unanimous vote at an annual or special general meeting.*

¹ Province of British Columbia, "Changes to Strata Legislation" subheading "Clarifying Strata User Fees for Common Property (March 2018) accessible at <https://www2.gov.bc.ca/gov/content/housing-tenancy/strata-housing/legislation-and-changes/changes-to-legislation> (accessed May 28, 2018).

² See Province of British Columbia "Common Expenses in Strata Corporations" accessible at <https://www2.gov.bc.ca/gov/content/housing-tenancy/strata-housing/operating-a-strata/finances-and-insurance/common-expenses> (accessed May 28, 2018).

³ BCUC Project No.1598941, accessible at: <http://www.bcuc.com/ApplicationView.aspx?ApplicationId=613> (accessed May 28, 2018).

- (3) *The resolution to approve a special levy must set out all of the following:*
- (a) *the purpose of the levy;*
 - (b) *the total amount of the levy;*
 - (c) *the method used to determine each strata lot's share of the levy;*
 - (d) *the amount of each strata lot's share of the levy;*
 - (e) *the date by which the levy is to be paid or, if the levy is payable in instalments, the dates by which the instalments are to be paid.*
- (4) *The strata corporation must*
- (a) *account for the money collected separately from other money of the strata corporation,*
 - (b) *invest all of the money collected in one or both of the following:*
 - (i) *investments permitted by the regulations;*
 - (ii) *insured accounts with savings institutions in British Columbia,*
 - (c) *use the money collected for the purpose set out in the resolution, and*
 - (d) *inform owners about the expenditure of the money collected.*
- (4.1) *A strata corporation may, by bylaw or by a resolution approving a special levy, establish a rate of interest, not to exceed the rate set out in the regulations, to be paid if an owner is late in paying his or her strata lot's share of the special levy.*
- (4.2) *Interest payable on a late payment of a special levy in accordance with a bylaw or resolution referred to in subsection (4.1) is not a fine, and forms part of the special levy for the purposes of section 116.*
- (5) *If the money collected exceeds the amount required, or for any other reason is not fully used for the purpose set out in the resolution, the strata corporation must pay to each owner of a strata lot the portion of the unused amount of the special levy that is proportional to the contribution made to the special levy in respect of that strata lot.*
- (6) *Despite subsection (5), if no owner is entitled to receive more than \$100 in total under subsection (5), the strata corporation may deposit the excess in the contingency reserve fund.*
- (7) *In subsections (4) and (5), "**money collected**" means the money collected on a special levy and includes any interest or income earned on that money.*

Alternatively, it can be spent from the contingency reserve fund under Section 96 of the *Strata Property Act*, which provides as follows:

The strata corporation must not spend money from the contingency reserve fund unless the expenditure is

- (a) *consistent with the purposes of the fund as set out in section 92 (b), and*
- (b) *approved or authorized as follows:*
 - (i) *the expenditure is first approved by a resolution passed by*
 - (A) *a majority vote at an annual or special general meeting if the expenditure is*
 - (l) *necessary to obtain a depreciation report under section 94, or*

(II) related to the repair, maintenance or replacement, as recommended in the most current depreciation report obtained under section 94, of common property, common assets or the portions of a strata lot for which the strata corporation has taken responsibility under section 72 (3), or

(B) a 3/4 vote at an annual or special general meeting if the expenditure is not described in clause (A) (I) or (II);

(ii) the expenditure is authorized under section 98.

1.8 Installation Costs

EVSE may be installed by an owner, occupant, or tenant, or by the strata corporation. If installed by an owner, occupant, or tenant, the owner, occupant, or tenant will need to obtain approval from the strata corporation (see above), and the strata corporation will likely request that the owner, occupant, or tenant sign an Alteration and Indemnity Agreement, agreeing to take responsibility for all costs related to the EVSE.

If EVSE is installed by the strata corporation, the strata corporation will need to do the following:

- if the installation constitutes a significant change in the use or appearance of common property, approve a resolution in accordance with Section 71 of the *Strata Property Act*;
- raise funds by way of special levy or authorize the use of the contingency reserve fund.

1.9 Cost Recovery

Electricity costs relating to common areas are billed directly to a strata corporation. Because they are the kind of expenses that occur either once a year or more often than once a year, they are operating fund expenses. In accordance with Section 97(b)(i) of the *Strata Property Act*, they are typically included in the strata corporation's annual budget. In accordance with Regulation 6.6 of the *Strata Property Act*, owners contribute to budget expenses by way of strata fees.

One reason that a strata council may be reluctant to approve a EVSE is that there is a perception that a user of the EVSE will be permitted to charge their vehicle at the expense of the strata corporation. Prior to March 7, 2018, although the strata corporation had the ability to impose user fees for the use of common property or common assets, it was believed that the strata corporation did not have the ability to calculate a user fee on the basis of the amount paid by the strata corporation on account of consumption by the user. This contributed to the perception that EV users would be charging their vehicles at the expense of the strata corporation

On March 7, 2018, Regulation **6.9** was amended to add subsection (2). It now states as follows:

(1) For the purposes of section 110 of the Act, a strata corporation may impose user fees for the use of common property or common assets only if all of the following requirements are met:

(a) the amount of the fee is reasonable;

(b) the fee is set out

(i) in a bylaw, or

(ii) in a rule and the rule has been ratified under section 125 (6) of the Act.

(2) A user fee imposed by a strata corporation may be a fixed amount or an amount determined on a reasonable basis, including, but not limited to, the following:

(a) the user's rate of consumption;

(c) the recovery of operating or maintenance costs by the strata corporation;

- (d) *the number of users;*
- (e) *the duration of use.*

A strata corporation is obligated to include electricity costs in its budget, and to charge for such costs by way of strata fees. However, Regulation 6.9 allows the strata corporation to charge a user fee for the use of the common property parking stall. As per the Regulation 6.9(2), the user fee can be calculated based on the user's rate of consumption. Provided that the strata corporation has (i) a bylaw or (ii) a rule which has been ratified under Section 125(6) of the *Strata Property Act*, the strata corporate has the right to charge a user fee.

Despite these amendments to the provincial *Strata Property Act* regulations, Measurement Canada, a federal agency responsible for ensuring accuracy in the selling of measured good, takes the position that a strata corporation may not charge strata owners on the basis of their individual energy (kWh) or demand (kW) use unless individual meters of a type approved by Measurement Canada are used to measure each strata owners' individual use.

Some strata councils have found that adding individual Measurement Canada-approved meters limits their choice of EVSE and adds significant cost to the use of the EVSE, particularly when compared to the relatively low cost of electricity consumed during normal use. Solutions that are, or could be employed, by some strata councils or networked charging providers on their behalf include:

- (1) billing a reasonable flat fee to all EVSE users in a building;
- (2) billing a reasonable flat fee adjusted in accordance with the efficiency of the users' EV as estimated by curb weight and average annual distance driven; or
- (3) billing based on charging time, as reported by the EVSE;
- (4) a priority system whereby priority charging is assigned to those who pay more, or based on Time of Use or other building demand loads or response to utility grid load requests;
- (5) payment of a service fee to a third party that supplies the EVEMS and EVSEs who in turn bears the expenses of the EVEMS and provides maintenance and repair, and may pay some of the costs of the electrical infrastructure.

Where electrical installation costs are paid by a third party, the legal documentation protecting that investment may not constitute a formal "mortgage" on common strata property, because Section 81 of the *Strata Property Act* prohibits a Strata Corporation from mortgaging common property of the corporation. In practise, some stratas may also be disregarding the Measurement Canada position by agreement with EVSE users but should be aware that a failure to comply with the *Weights and Measures Act*, which provides Measurement Canada with its authority on this point, could lead to monetary penalty.