



Contract 3483Q

Supply and Delivery of ACCESS HATCH FOR ECKERSLEY A SANITARY PUMP STATION

Bidders are requested to respond to this Quotation call as instructed subject to the provisions contained herein.

Name of Bidder: _____

Address: _____

City: _____

Province: _____ Postal Code: _____

Telephone No: _____ Fax No.: _____

E-mail: _____

Contact Person: _____

Title: _____

Table of Contents

Cover Page	1
Table of Contents	2
Instructions to Bidders	3
Quotation Form	6
Schedule of Quantities and Prices	7
List of Previous Contracts	8
Specifications	9
List of Drawings	10
Environmental Terms and Conditions of Contract	11
General Conditions of the Contract	GC1-GC4
Notice of No Bid	

Instructions to Bidders

1. Two copies of quotations, sealed and plainly marked on the envelope:

**CONTRACT 3483Q - SUPPLY AND DELIVERY OF ACCESS HATCH FOR
ECKERSLEY A SANITARY PUMP STATION**

will be received at the Information Counter, Main Floor, Richmond City Hall, addressed to the Purchasing Section, 6911 No. 3 Road, Richmond, BC, V6Y 2C1, until 3:00pm, Local time:

Tuesday April 14, 2009

2. Quotations received in the office of the Purchasing Section after the above-mentioned time and date will be returned unopened.
3. Quotations must be submitted on the attached Forms and be authorized by a signing officer of the Bidder's company. The entire Request for Quotation must be returned to the City.
4. This Document with completed Forms will become part of the Contract Documents between the City and the successful Bidder.
5. The City reserves the right to accept all or any part of a quotation or to waive irregularities at their own discretion. The lowest or any quotation will not necessarily be accepted.
6. In accordance with the City's Procurement Policy 3104, award of bids shall be based on:
 - (i) The lowest total cost of acquisition,
 - (ii) Experience of the bidder,
 - (iii) Bidder's references of performance on previous similar contracts,
 - (iv) The bidder's financial resources,
 - (v) Bidder's capability of supervision, staffing and use of subcontractors,
 - (vi) Bidder's ability to meet City specifications and performance criteria,
 - (vii) Any additional evaluation criteria stated in the contract document.
7. The City of Richmond estimates that this contract will be awarded within 4 - 6 weeks of the closing date. All bidders submitting Quotations for the Project will be advised as to the outcome. Please note that Bid results for those contracts posted on the City Web Site and/or BC Bid will be listed on BC Bid within two (2) weeks of the award of Contract.
8. Proprietary names, unless otherwise stated, are used solely to establish standards of materials and finish. Items of other manufacture may be accepted as equal to those specified, at the discretion of the City.
9. Alternate Quotations will be considered and should be submitted under separate cover and be marked "Alternate Quotation".

Instructions to Bidders (Cont'd)

10. Prices, in Canadian currency, shall be shown for each unit specified and shall include all packing, crating, freight, cartage, shipping charges, cost of unloading supplies at destination, and all tariffs, taxes and duties.

11. Inquires during submission of Quotation should be directed as follows:

Purchasing

Kerry Lynne Gillis
Buyer II - Contracting Specialist
Purchasing Section
City of Richmond

Telephone: 604-276-4135
E-mail: purchasing@richmond.ca

Technical

Anthony Fu, EIT
Project Manager
Engineering & Public Works
City of Richmond

Telephone: 604-247-4905
E-mail: afu@richmond.ca

12. Quotations may be withdrawn by written notice only, provided such notice is received at the office of the City's Purchasing Section prior to the date / time set as the closing time for receiving Quotations.

13. Quotations shall be open for acceptance for 60 days following the submission closing date.

14. Supply and delivery of the completed kiosk shall be within sixteen (16) weeks of contract award. Bidders must provide a detailed supply and delivery schedule. Delivery will be made to the City of Richmond works yard at 5599 Lynas Lane in Richmond. Supplier to coordinate delivery to the works yard with Dermott Pitts at 604-244-1269.

15. Each Bidder shall state on the list provided to be submitted as part of his quotation, information regarding their previous Contracts. It is the intention of the City not to award the contract to any Bidder who does not furnish satisfactory evidence that he has the ability and experience to perform the various works covered under this Contract, and that he has sufficient capital and plant to enable him to execute the said works successfully, and to the satisfaction of the City, and to complete and deliver said works as quoted in his Quotation.

16. Bidders are advised that submissions of quotes shall be in compliance to the Freedom of Information and Privacy Act (BC).

17. Any interpretation of, additions to, deletions from, or any other corrections to the Contract documents, will be issued as written addenda by the City of Richmond. It is the sole responsibility of the potential bidders to check with the City of Richmond's Website and / or BC Bid to ensure that all available information has been received prior to submitting a bid.

Instructions to Bidders (Cont'd)

18. The City, it's agents and employees shall not be responsible for any information given by way of verbal communication.

19. Except as expressly and specifically permitted in these Instructions to Bidders, no bidder shall have any claim for any compensation of any kind whatsoever, as a result of participating in the RFQ, and by submitting a quotation each bidder shall be deemed to have agreed that it has no claim.

Quotation Form

Purchasing Section
City of Richmond
6911 No. 3 Road
Richmond, BC V6Y 2C1

The undersigned Bidder, having carefully read and examined the Instructions to Bidders, Quotation Form, Schedule of Quantities and Prices, General Conditions of Contract, and Specifications, and having full knowledge of the work required, does hereby offer to provide all necessary materials in strict accordance with the Specifications and to do all therein called for on the terms and conditions and under the provisions therein set forth at the:

LUMP SUM TOTAL QUOTED PRICE OF \$ _____

PAYMENT TERMS _____ **EARLY PAYMENT TERMS** _____

The above price includes and covers duties, Federal, (including G.S.T.), Provincial Taxes, handling and transportation charges, and all other charges incidental to and forming part of this Quotation.

The undersigned Bidder agrees to supply the whole of the materials within _____ weeks of acceptance (**not to exceed 16 weeks**).

Name of Bidder: _____

Address: _____

Telephone No: _____

Name, Signature,
and Title of
Signing Officer: _____

Date: _____

E-mail: _____

Web Address: _____

Schedule of Quantities and Prices

The City shall pay in Lawful money of Canada the amount shown for the following items subject to the conditions of the Contract Documents.

ITEM DESCRIPTION	QUANTITY	UNIT PRICE	EXTENSION
Sanitary Pump Station Access Hatch	1	\$ _____	\$ _____

Subtotal \$ _____

Provincial Sales Tax \$ _____

Goods and Services Tax \$ _____

TOTAL QUOTED AMOUNT \$ _____
(carried forward to Quotation Form)

Initials of Signing Officer

List of Previous Contracts

The Bidder has recently undertaken and completed the Contracts described following and authorizes the City of Richmond to inquire as to the nature of the Bidders performance on these contracts.

YEAR	PROJECT TITLE	OWNER PHONE # CONTACT	SCOPE	BUDGET		SCHEDULE		ROLE OF KEY STAFF MEMBERS	OTHER RELEVANT INFO
				Original	Actual	Proposed	Actual		

(If additional space is required, attach additional)

Specifications

- Doors are to be 300 lb load rated double leaf hatches
- Constructed from 1/4" aluminium plate with checker plate safety tread.
- Hinges are to be heavy brass with tamper proof stainless steel hardware or better.
- Doors shall be equipped with stainless steel compression spring operators or equal capacity gas springs for easy operation.
- Frames to be 1/4" extruded aluminium channel type frame with an integral anchor flange.
- Frames to be equipped with a 1.5" drain at each corner.
- Doors shall have an automatic hold open arm with a release handle and a flush drop handle along with a slam lock.
- Doors shall have an oversized recessed space for a padlock.
- Hatch require a gasket around the hatch to limit the escape of odours from the sewage wet well beneath.
- Sized as shown on the attached drawings
- Prices are to include all duties, taxes etc. to deliver the hatches F.O.B. to the City of Richmond works yard.

List of Drawings

<u>Drawing No.</u>	<u>Sheet No.</u>	<u>Revision</u>	<u>Title</u>
<u>0946-08-OC-003</u>	<u>3 OF 5</u>	P2	Wet Well Plan & Section

Note:

Full sized copies of the drawings can be obtained by calling Anthony Fu, EIT., Engineering Design and Construction, at 604-247-4905.

Environmental Terms and Conditions of Contract

1.0 Environmental Policy Requirements

1.1 The City of Richmond's Environmental Purchasing Policy

The City of Richmond's Environmental Purchasing Policy states:

In order to increase the development and awareness of environmentally sound products and services, City of Richmond staff will review their contracts and tender specifications for goods and services, to ensure that wherever possible and economically feasible, specifications are amended to provide for consideration of environmental characteristics. Consideration may be given to those environmental products that are certified by an independent accredited organization.

The City of Richmond as a whole will endeavour to increase its use of products and services that are more responsible to the environment in the way they are made, used, transported, stored and packaged and disposed of. It is recognized that analysis is required in order to ensure that the products are made available at competitive prices, and that the environmental benefits provided by a product or service should not significantly affect the intended use of that product or service.

- 1.1.1 The City of Richmond reserves the right to request information from bidders that will demonstrate compliance to this environmental purchasing policy.
- 1.1.2 Bidders are asked to supply information on environmentally preferable products and services that meet all specifications and performance requirements.
- 1.1.3 Placing the City of Richmond in breach of its environmental policy or environmental laws will result in the termination or suspension of an agreement, at the sole discretion of the City.

1.2 Environmental purchasing resources

- 1.2.1 The City of Richmond Environmental Purchasing Guide is available from the City of Richmond Web site at:

<http://www.richmond.ca/services/environment/policies/purchasing.htm>

General Conditions of the Contract

1. Definitions

The two parties to the contract/Purchase Order. are the Contractor and the City, defined as follows:

The Contractor: The successful bidder for the work upon receipt of a purchase order and/or written acceptance of his Quotation from the City.

The City: City of Richmond.

Acceptance of the City of Richmond Purchase Order deems acceptance of all conditions of the Supply and Delivery Contract.

2. Responsibility For Supplies

The Contractor shall be responsible for the supplies covered by this contract until they are delivered at the designated delivery point, regardless of the point of inspection; and the contractor shall bear all risks of loss or damage to rejected supplies after notice of rejection.

3. Inspection

All supplies shall be subject to inspection and test by and shall meet the approval of the Manager of Purchasing and Risk and his decision shall be final and binding upon all parties.

In case any supplies or lots of supplies are defective in material or workmanship otherwise not in conformity with the specifications of the contract, the Manager of Purchasing and Risk shall have the right either to reject them or to require their correction.

Acceptance or rejection of the supplies shall be made as promptly as practicable after delivery, but failure to inspect and accept or reject supplies shall not relieve the contractor from responsibility for such supplies as are not in accordance with the specifications.

4. Warranty

Unless otherwise specified, the contractor warrants that in the manufacture of the supplies only the best workmanship and materials have been employed and if, within a period of one (1) year from the date of acceptance of the supplies by the City, such supplies or any portion thereof are found by the City to be defective or faulty due to

General Conditions of the Contract (Cont'd)

imperfect or bad workmanship or material, the contractor agrees, to replace such defective supplies forthwith without expense to the City.

5. Payments

The contractor shall be paid within 30 Days after the submission by the contractor of properly prepared invoices to the Accounts Payable Section for supplies delivered and accepted or services rendered and accepted. However, the City may withhold an amount equal to two times the value of goods or services not provided by the Contractor from any amounts owing to the Contractor.

6. Indemnification and Insurance

The Contractor will indemnify, hold and save harmless the City from and against all claims, losses, damages, costs, actions and other proceedings, made, sustained, brought or prosecuted in manner, based upon, occasioned by attributable to any injury, including death, property damage, infringement or damage arising from any act or omission of the Contractor, his employees, officers, volunteers, servants or agents or persons from whom the Contractor has assumed responsibility in the performance or purported performance of this agreement.

7. Liens

The Contractor shall fully indemnify the City from and against any and all liability or expenses by way of legal costs or otherwise in respect of any claim which may be made for a lien or charge at law or inequity or to any claim or liability under the Builders Lien Act, or to any attachment for debt, garnishee process, or otherwise.

8. Patent Fees

The Contractor shall pay all royalties and licence fees and shall save the City harmless from loss on account of suits or claims of infringement of patents in the doing of the work.

9. Default

- (a) The City may, by notice of default to the contractor, terminate the whole or any part of this contract if the contractor fails to make delivery of the supplies within the time specified, or to perform any other provisions of this contract.
- (b) In the event the City terminates this contract in whole or in part as provided in clause (a) the City may procure supplies or services similar to those so terminated, and the contractor shall be liable to the City for any excess costs for such similar supplies or services.

General Conditions of the Contract (Cont'd)

- (c) The contractor shall not be liable for any excess costs under clause (b) if failure to perform the contract arises by reason of strikes, lockouts, acts of God or acts of the City.

10. Taxes

Unless otherwise provided herein, the Contractor shall pay all government sales or excise taxes in force at the date of the Contract/Purchase Order, provided that any increase or decrease in such taxes shall increase or decrease the amount due under the Contract accordingly. Invoices must show the appropriate amounts for Goods and Services Taxes and Provincial Sales Taxes separately.

11. Laws

The laws of British Columbia shall govern the work.

12. Time

Time shall be the essence in this Contract.

13. Assignment

Neither party to the Contract shall assign the Contract without the written consent of the other.

14. Changes

The City may make changes to the Contract and time and value shall be adjusted accordingly, except for emergencies all changes shall be made by written order.

15. Notices

Any notice required to be given in this Contract shall be deemed to be duly given to the City if sent by registered mail addressed to the City's Purchasing and Risk Manager at "City Hall, 6911 No. 3 Road, Richmond, BC V6Y 2C1" and to the Contractor if sent by registered mail addressed to the Contractor at the address set forth in the Quotation.

16. No Promotion of Relationship with the City, the Olympic Oval or the 2010 Olympic and Paralympic Winter Games

The Contractor shall not disclose or promote its relationship with the City, including by means of any verbal declarations, announcements, sales, marketing or other literature, letters, client lists, press releases, brochures or other written materials (the Communications") without the express prior written consent of the City (except as may

General Conditions of the Contract (Cont'd)

be necessary for the Contractor to perform the Contractor's obligations under the terms of this Agreement).

Furthermore, the Contractor undertakes not to disclose or promote its relationship with the City in any Communications in a manner which could suggest or create an association, express or implied, between the Contractor and the International Olympic Committee, the 2010 Olympic and Paralympic Winter Games, the Olympic Movement or the Vancouver Organizing Committee for the 2010 Olympic and Paralympic Winter Games (also known as "VANOC"). Without limiting the generality of the foregoing, the Contractor shall not refer to "VANOC", "Vancouver 2010", the "2010 Games", the "Games", "**Venue City**", "Olympic", "Olympic Oval" or "Olympics", and shall not use any official emblem, logo or mascot of the 2010 Games, the City or the Richmond Olympic Oval in any Communications, without the express prior written consent of the City, which may be withheld.



Note: Receipt of this completed form will assist us in calling for future bids. Please complete and submit this form prior to the closing date and time as shown on the Request for Quotation/Proposal/Tender form.
Please remember to include Quotation/Proposal/Tender No. at right.

Quotation/Proposal/Tender No.

3483Q

A Quotation/Proposal/Tender is not being submitted for the following reason(s):

- | | |
|--|--|
| <input type="checkbox"/> We do not manufacture/supply the required goods/services | <input type="checkbox"/> Cannot obtain raw materials/goods in time to meet delivery requirements |
| <input type="checkbox"/> We do not manufacture/supply to stated specifications | <input type="checkbox"/> Cannot meet delivery requirements |
| <input type="checkbox"/> Specifications are not sufficiently defined | <input type="checkbox"/> Cannot quote/tender a firm price at this time |
| <input type="checkbox"/> Insufficient information to prepare quote/proposal/tender | <input type="checkbox"/> Insufficient time to prepare quote/tender. |
| <input type="checkbox"/> Quantity too small | <input type="checkbox"/> We are unable to competitively quote/tender at this time. |
| <input type="checkbox"/> Quantity too large | <input type="checkbox"/> We do not have facilities to handle this requirement |
| <input type="checkbox"/> Quantity beyond our production capacity | <input type="checkbox"/> Licensing restrictions (please explain) |
| <input type="checkbox"/> Cannot meet packaging requirements | <input type="checkbox"/> Agreements with distributors/dealers do not permit us to sell directly. |
| <input type="checkbox"/> Cannot handle due to present plant loading | <input type="checkbox"/> Other reasons or additional comments (please explain below) |

I / We wish to quote / tender on similar goods / services in future <input type="checkbox"/> Yes <input type="checkbox"/> No	Authorized Company Official – Signature and Title	Date
This space for City of Richmond Comments	Firm Name	
	Address	
	City	
	Province Postal Code	
	Telephone Number	

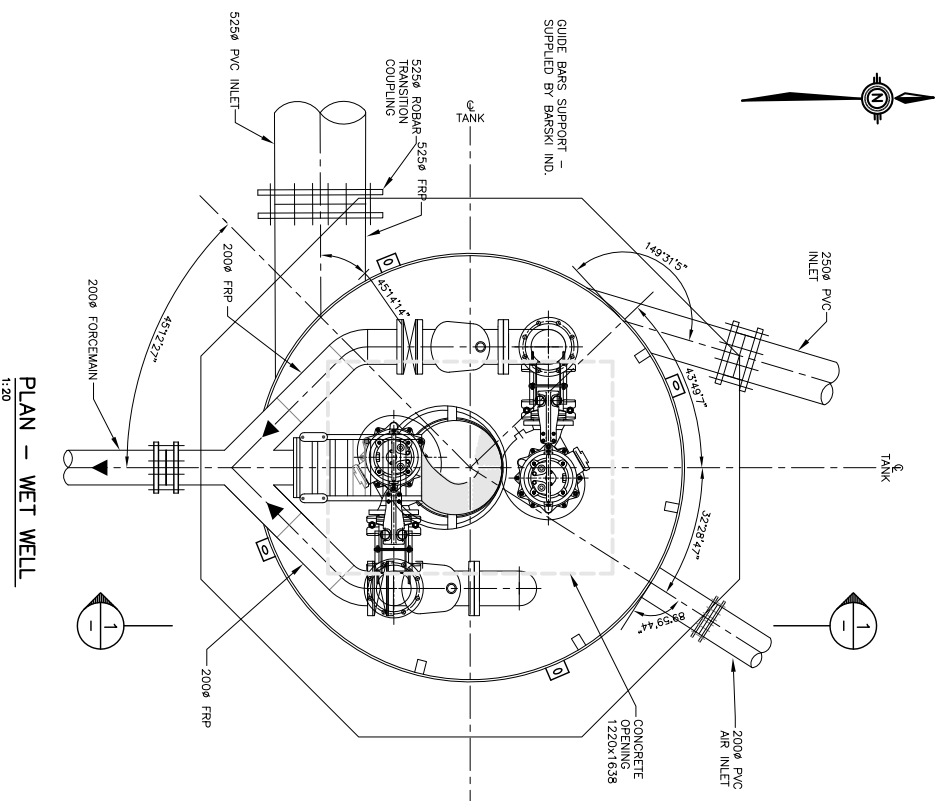

PLAN - WET WELL
1:20

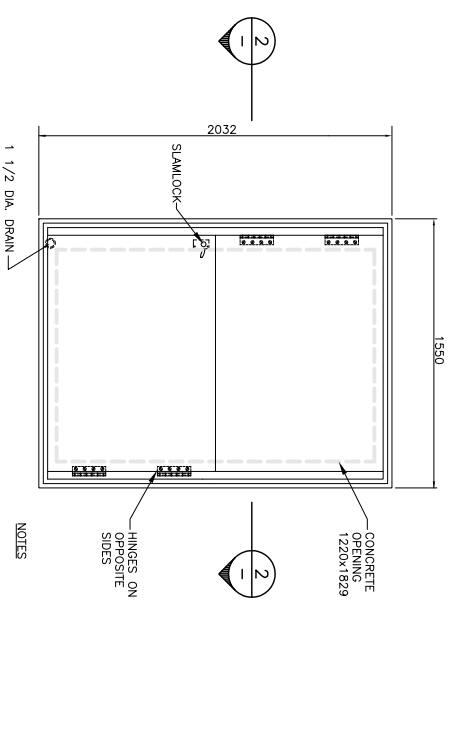

PLAN - WET WELL HATCH
1:20

NOTES
1. 300lb/sq.ft. DESIGN LOADING

SECTION
1:20

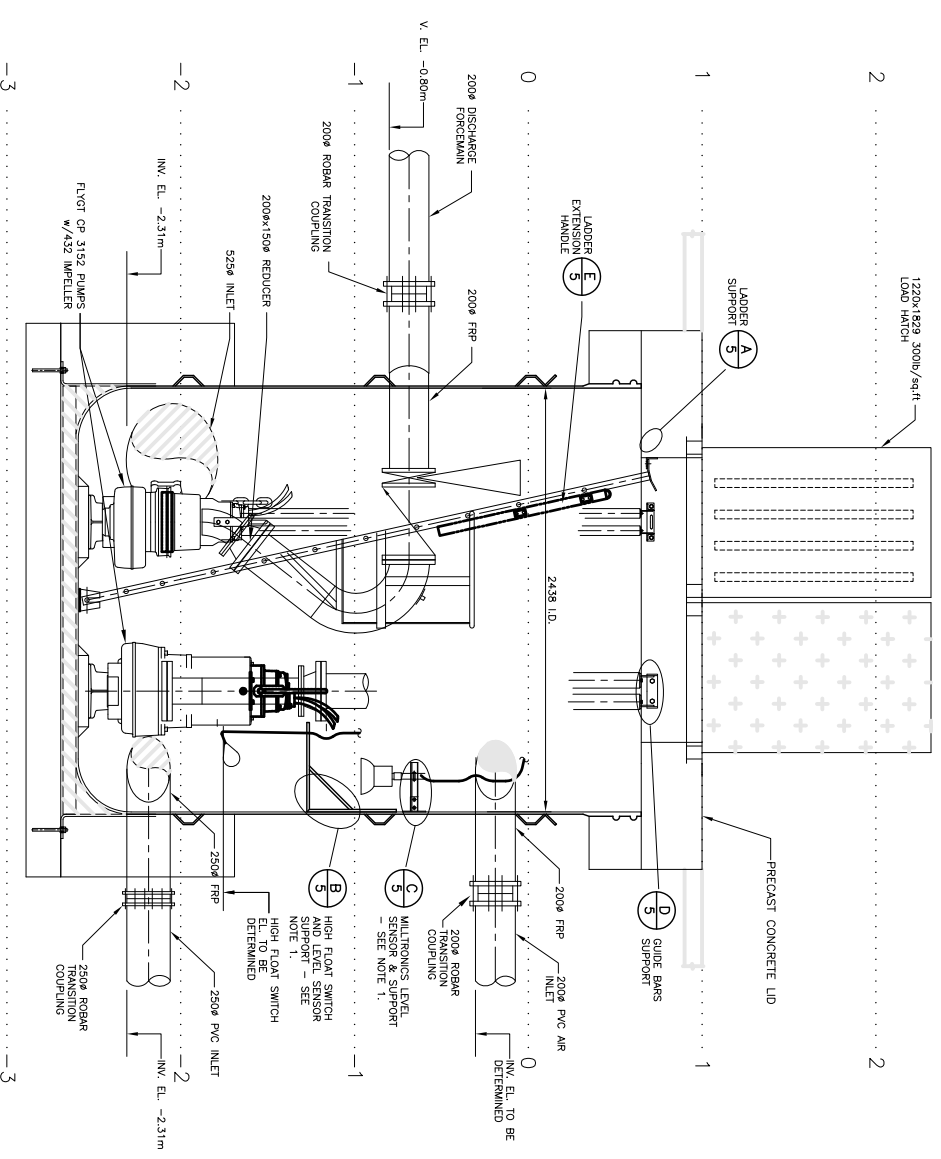
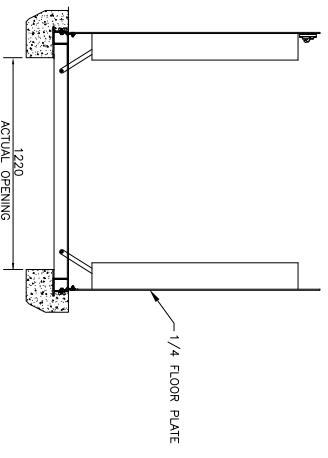

SECTION
1:20

NOTES
1. LOCATION TO BE DETERMINED IN SHOP DRAWINGS.

B.C. GAS SERVICES

THE DEVELOPER OR CONTRACTOR SHALL BE RESPONSIBLE FOR DETERMINING EXISTING LOCATION OF GAS SERVICE LINES, AND WHERE NECESSARY ARRANGE FOR THEIR RELOCATION IN ORDER TO FACILITATE INSTALLATION OF THE WORKS SHOWN ON THESE PLANS. A LIST OF SERVICE LINE LOCATIONS MAY BE OBTAINED FROM:

B.C. 1.041
TELEPHONE: 604-474-4888
CELLULAR: 4888
NOTE - B.C. GAS REQUIRES 10 DAYS NOTICE PRIOR TO THE COMMENCEMENT OF ANY WORK.

BENCHMARK

ALL ELEVATIONS ARE TO GEODETIC DATUM AND REFER TO RICHMOND BENCHMARK NUMBER:
MONUMENT NO. 774-4889 AT CENTRELINE OF ST. ALBANS ROAD AND BUNDELL ROAD
ELEVATION: 1.251m
FIELD BOOK #:
CITY WORK ORDER #:
CONTRACT WORK ORDER #:

REFERENCE DRAWINGS

PROPERTY ACQUISITION
SITE PLAN & PROFILE
ROAD CONSTRUCTION
STORM SEWER INSTALLATION
WATERMAIN INSTALLATION
ORIGINATING STREET LIGHTING
TRAFFIC SIGNALS
SEWER SEWER INSTALLATION
OTHER

NO.	DATE	BY	CHKD.	DESCRIPTION
P2	2009/03/17	MJ	KW	ISSUED FOR PRE-PURCHASE
P1	2009/07/16	MJ	KW	ISSUED FOR CLIENT REVIEW

TITLE

ECKERSLEY 'A' SANITARY
PUMP STATION UPGRADE
WET WELL
PLAN AND SECTION

City of Richmond
6911 NO. 3 ROAD RICHMOND B.C. V6Y 2C1



4101 - 1861 Welch St.
North Vancouver B.C.
Telephone: (604) 985-0508
Fax: (604) 985-0536

DESIGNER:	KW	DATE:	JUNE 2008
DRAWN:	MJ	SCALE:	AS SHOWN
CHECKED:	KW	SEC. NO.:	3 OF 5
ENGINEER:	KW		