



**Contract 3194P APS (Accessible Pedestrian Signals)**

**1. Introduction**

The City of Richmond proposes to engage the services of a company that can supply and deliver Accessible Pedestrian Signals (APS) for use at different types of traffic signal devices within the City of Richmond.

The objective of this request for proposal is to provide the City with qualified proponents capable of carrying out the work herein defined. The subsequent proponent submissions will form the basis for evaluation, interview and selection.

**2. Submission Details**

Two copies of proposals marked “ **Contract 3194P**” addressed to the Purchasing Section, will be received at the Information Counter, Main Floor, Richmond City Hall, 6911 No. 3 Road, Richmond BC V6Y 2C1, **until 1:00pm, Monday, May 30, 2008**. Submissions received after this time will be returned to the sender.

The City reserves the right to cancel this Request for Proposal for any reason without any liability to any proponent or to waive irregularities at their own discretion.

Proposals may be withdrawn by written notice only provided such notice is received at the office of the City’s Purchasing Section prior to the date/time set as the closing time for receiving proposals.

Proposals shall be open for acceptance for 90 days following the submission closing date.

All proposals will remain confidential, subject to the Freedom of Information and Privacy Act.

Any interpretation of, additions to, deletions from, or any other corrections to the Proposal document, will be issued as written addenda by the City of Richmond. It is the sole responsibility of the potential Bidders to check with the City of Richmond’s Website, and / or BC Bid to ensure that all available information has been received prior to submitting a bid.

Except as expressly and specifically permitted in these instructions, no Proponent shall have any claim for any compensation of any kind whatsoever, as a result of participating

in the RFP, and by submitting a proposal each proponent shall be deemed to have agreed that it has no claim.

### 3. Enquiries

3.1 Clarification of terms and conditions of the proposal process shall be directed to:

Purchasing

Daianna Panni, Buyer  
Purchasing Department  
Business & Financial Services Division  
City of Richmond

Telephone: 604-276-4270  
E-mail: [purchasing@richmond.ca](mailto:purchasing@richmond.ca)

3.2 Technical clarification shall be directed to:

Technical

Steve Matheson, Traffic Technician II (Signals)  
Traffic Signal Operations Department  
Planning and Development Division  
City of Richmond

Telephone: 604- 276-4033  
E-mail: [smatheson@richmond.ca](mailto:smatheson@richmond.ca)

or

Jeff Bycraft, Traffic Signal Systems Technologist  
Traffic Signal Operations Department  
Planning and Development Division  
City of Richmond

Telephone: 604-276-4031  
E-mail: [jbycraft@richmond.ca](mailto:jbycraft@richmond.ca)

The City, its agents and employees shall not be responsible for any information given by way of verbal communication.

Any questions that are received by City of Richmond Staff that affect the Proposal Process will be issued as addenda by the City of Richmond.

### 4. Project Background

The objective of this project is to install APS devices, based upon priority of location, at different types of traffic signal devices including full traffic signals, pedestrian activated traffic signals and Special Crosswalks, which are crosswalks with overhead illuminated signs, down lighting and pedestrian actuated flashing amber beacons..

The proponent shall supply and deliver APS units with varying features for each type of traffic signal device as outlined below in Project Scope.

## 5. Project Scope

### 5.1 General:

5.1.1) APS device shall have the ability to install the City's standard round or rectangular pushbutton, supplied by the City. Dimensions of these buttons can be found in exhibit 1. (The proponent shall take into account the incorporation of the round and/or rectangular buttons in their proposal.)

5.1.2) It is the City's intent to maintain the use of its current pushbutton signs as shown in exhibit 2. (For information only.)

5.1.3) APS device shall have the ability to easily retrofit an external speaker (for beaconing) to be mounted on or near the pedestrian signal head.

5.1.4) It is the City's desire to progress towards the capability to remotely communicate to APS devices from the Central Traffic Signal Control Centre for the purpose of equipment status monitoring and uploading/downloading programmable features. The proponent shall outline their qualifications towards this capability.

**5.2 To supply and deliver APS devices for full traffic signals and pedestrian activated traffic signals with the ability to deploy features as outlined in the 2007 TAC "Guidelines For Understanding, Use and Implementation of Accessible Pedestrian Signals".**

**5.3 To supply and deliver APS devices for Special Crosswalks with the ability to deploy features as outlined in the 2007 TAC "Guidelines For Understanding, Use and Implementation of Accessible Pedestrian Signals" with the following exceptions.**

5.3.1) Tactile arrow is non vibrating.

5.3.2) The default audible indication tone for this type of traffic signal device shall be a rapid fire pole locator tone which would be active during the amber flashing stage (crosswalk occupied) and the duration/volume of this tone to be fully programmable and be reactive to ambient sound as is the case with APS for other traffic signal devices.

## 6. City Provided Items

Pushbuttons. (Upon request.)

## 7. Site visit

N/A

**8. Budget**

N/A

**9. Project Schedule**

A project schedule is to be submitted with the proposal outlining milestone dates for a prototype to be manufactured and tested. The schedule shall show how long after acceptance of the prototype to when full production and delivery can be made.

**10. Proposal Submissions**

All proponents are required to provide the following information with their submissions, and in the order that follows:

- A Corporate profile of their firm outlining its history, philosophy and target market.
- A detailed listing of APS experience in research, development, manufacturing and sales.
- A description of the proponent's understanding of the project objectives/outcomes and vision, and how these will be achieved.
- A detailed project methodology explaining each project task including what will be expected of both the proponent and the City with respect to each task.
- Team Composition – a complete listing of all key personnel who will be assigned to this project. This will include their relevant experience, qualifications for this project, roles and responsibilities, leadership, etc., in addition to their availability for this project. Also, any committees that your company or staff are members of or are involved with as related to APS, eg., Canadian National Institute for the Blind (CNIB), etc.
- A detailed proposal of what will be delivered, including the expected outcome and benefits to the City of Richmond.
- A detailed schedule of all activities, including milestones, project meetings, interim reports and progress reports required for this project.
- A minimum of three (3) client references from other APS projects.
- A cost of the finished product (not including field installation). Initial orders will be approximately 100 units for traffic/pedestrian signals and 100 units for special crosswalks.

- A delivery schedule
- A list of enhancements, options or features that are available and are not identified within the TAC “Guidelines for Understanding, Use and Implementation of Accessible Pedestrian Signals” or within this call for proposal.

#### **11. Working Agreement**

The successful proponent will enter into a contract for services with the City based upon the information contained in this request for proposal and the successful proponent’s submission and any modifications thereto.

#### **12. Evaluation Criteria**

Proposals shall be evaluated to determine the best value offered to the City against conformance to the following criteria: (not listed in priority.)

- Understanding of project objectives/outcomes and vision
- Project Methodology
- Team Composition – Experience and Qualifications of the company/staff to be assigned to the project.
- Project Deliverables including prototype and finished product
- Warranty
- Additional product enhancements
- Installation methodology
- Quality of product
- Technical support (including location, availability and experience)
- Delivery schedule (available stock)
- Value for Money
- References
- Interview (if required)



**City of Richmond**  
Business & Financial Services Department

**Notice of No Bid**

**Note:** Receipt of this completed form will assist us in calling for future bids. Please complete and submit this form prior to the closing date and time as shown on the Request for Quotation/Proposal/Tender form.  
Please remember to include Quotation/Proposal/Tender No. at right.

Quotation/Proposal/Tender No.  
**3194P**

**A Quotation/Proposal/Tender is not being submitted for the following reason(s):**

- |  |  |
|--|--|
| <input type="checkbox"/> We do not manufacture/supply the required goods/services  | <input type="checkbox"/> Cannot obtain raw materials/goods in time to meet delivery requirements |
| <input type="checkbox"/> We do not manufacture/supply to stated specifications     | <input type="checkbox"/> Cannot meet delivery requirements                                       |
| <input type="checkbox"/> Specifications are not sufficiently defined               | <input type="checkbox"/> Cannot quote/tender a firm price at this time                           |
| <input type="checkbox"/> Insufficient information to prepare quote/proposal/tender | <input type="checkbox"/> Insufficient time to prepare quote/tender.                              |
| <input type="checkbox"/> Quantity too small  | <input type="checkbox"/> We are unable to competitively quote/tender at this time.               |
| <input type="checkbox"/> Quantity too large  | <input type="checkbox"/> We do not have facilities to handle this requirement                    |
| <input type="checkbox"/> Quantity beyond our production capacity                   | <input type="checkbox"/> Licensing restrictions (please explain)                                 |
| <input type="checkbox"/> Cannot meet packaging requirements                        | <input type="checkbox"/> Agreements with distributors/dealers do not permit us to sell directly. |
| <input type="checkbox"/> Cannot handle due to present plant loading                | <input type="checkbox"/> Other reasons or additional comments (please explain below)             |

I / We wish to quote / tender on similar goods / services in future <input type="checkbox"/> Yes <input type="checkbox"/> No	Authorized Company Official – Signature and Title	Date
This space for City of Richmond Comments		Firm Name
		Address
		City
		Province <span style="float: right;">Postal Code</span>
		Telephone Number

# EXHIBIT 1

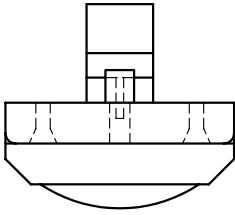

TOP VIEW

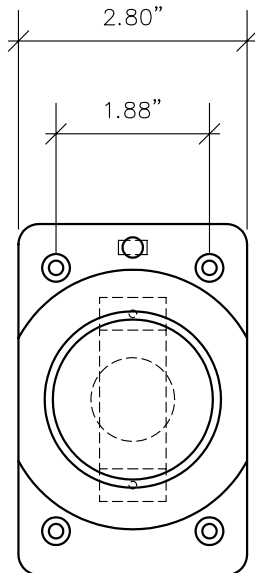

FRONT VIEW

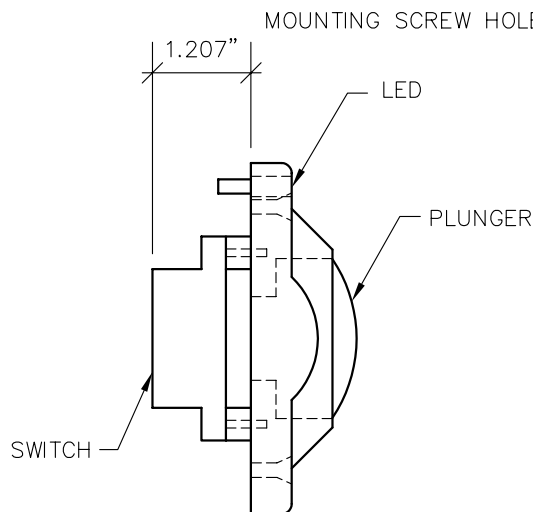

SIDE VIEW

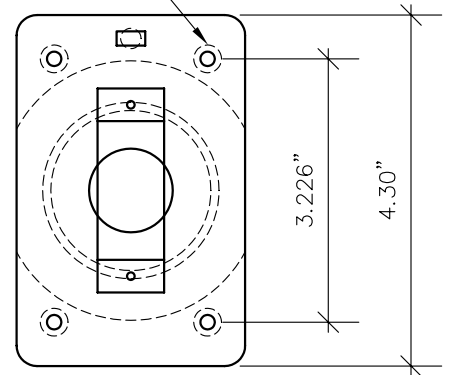

REAR VIEW

NOTE: THIS DRAWING TO BE USED AS REFERENCE ONLY. DIMENSIONS SHOWN ARE APPROXIMATE. SAMPLE PUSH BUTTONS ARE AVAILABLE UPON REQUEST.

TITLE:

BULLSEYE PEDESTRIAN PUSH BUTTON

DESIGN:

DRAWN: S.L.M.

DWG. No. BULLSEYE.DWG

CHECKED:

SCALE: N.T.S.

DATE: MAY 2008

ENGINEER:

SEC. No.

SHT. No. 1 of 1

# EXHIBIT 2

305mm



229mm

**PUSH BUTTON SIGN FOR  
TRAFFIC/PED. SIGNALS**



229mm

**PUSH BUTTON SIGN FOR  
SPECIAL CROSSWALKS**





City of Richmond

**Fax Cover Sheet**

---

<b>To:</b>	<b>Name:</b> TO THOSE WHO HAVE <b>Company:</b> RECEIVED COPIES OF 3194P	<b>File:</b> 02-0775-50-3194-PQ/Vol 01	<b>Date:</b> May 12, 2008	<b>Fax:</b>
------------	--	---	---------------------------	-------------

---

<b>From:</b>	<b>Department:</b> Purchasing	<b>Phone:</b> 604-604-4270
	<b>Name:</b> Daianna Panni	<b>Fax:</b> 604-604-4162

**If you have any problems with this fax, contact: at 604-276-4270**

---

Total no. of pages, including cover sheet:  
Mailed original to follow:

---

**Message:**

**Re: RFP 3194P**  
**Addendum No. 1**  
**APS ( Accessible Pedestrian Signals)**

**Please note the following changes on Page 3, section 5.1.1 .**

**Existing:**

*APS device shall have the ability to install the City's standard round or rectangular pushbutton, supplied by the City.*

**Replace with:**

*APS device shall have the ability to install the City's standard rectangular pushbutton, supplied by the City.*

**The words "round" have been removed.**

Yours truly

Daianna Panni  
Buyer I  
City of Richmond



## City of Richmond

6911 No. 3 Road  
Richmond, BC V6Y 2C1

## Fax Cover Sheet

---

**To:** Name: All companies receiving copies of the Request for Tender Document – **3194P – APS (Accessible Pedestrian Signals)**

Company:

**File:** 02-0775-50-3194-PQ/Vol 01

**Date:** May 13, 2007

**Fax:** Various

---

**From:** Department: Business & Financial Services Department

Name: Daianna Panni  
Buyer, Purchasing

**Phone:** 604-276-4287

**Fax:** 604-276-4270

**If you have any problems with this fax, contact: Daianna Panni at 604-276-4270**

---

Total no. of pages, including cover sheet: 1

Mailed original to follow:  No

urgent

for your action

---

**Message: Request for Tender 3194P – APS (Accessible Pedestrian Signals)**

### **Addendum Number 2**

Please find addendum Number 2 for the above referenced project.

***This Request for Proposal is now “ON HOLD” until further notice.***

We apologise for any inconvenience that this may cause you and look forward to receiving your submission.

Sincerely,

Daianna Panni,  
Buyer

**IMPORTANT - CONFIDENTIAL INFORMATION**

THIS MESSAGE IS INTENDED ONLY FOR THE USE OF THE INDIVIDUAL OR ENTITY TO WHICH IT IS ADDRESSED AND MAY CONTAIN INFORMATION THAT IS PRIVILEGED, CONFIDENTIAL AND EXEMPT FROM DISCLOSURE UNDER APPLICABLE LAW. Any other distribution, copying, or disclosure is strictly prohibited. If you have received this message in error, please notify us immediately by telephone and return the original transmission to us by mail without making a copy.  
2451551

