

MEGA STAGE

DYNA  STAGE™

Model 24 20 15 MKII



This new generation of Dynastage 24 20 15 mobile stage is built to move: lighter, tougher and just as easy to set-up.



Welcome to the Dynastage 24 20 15 Mark II !

*We are pleased to introduce the new generation of Dynastage products. Mark II models represent a very significant evolution of the proven Dynastage line. With its **more efficient design**, it allows to suspend 30% more weight than its predecessors. Set-up is even easier than before with improvements at all stages of installation: from the towing apparatus to the legs, from improved hydraulics and controls to better hanging points and supports, easier access to the cargo area, and so on.*

*Mega-Stage is also proud to announce that throughout the entire design process of new Mark II models, its R&D department uses virtual 3D models. The benefits are twofold: no design flaw can make it into the real world and, should the need for repairs arise, exploded views can be quickly provided to any qualified shop around the world along with detailed procedures. The result is an **even more rugged design**, incorporating 100-tons test titanium bolts and nuts throughout, and other fabrication improvements.*

As with all Mega-Stage products, the 24 20 15 MKII is built with one objective in mind: Get the show on the road easily, as fast as possible, and make sure it will go on for as long as you want to. As rugged and durable as they are, Dynastage products are typically submitted to a lot of wear and tear. That's the nature of the business. This is why we built them for easy maintenance, with safety rated and clearly labelled user replaceable hanging points and other improvements that will help you keep your show on the road and on schedule.

In this manual, we will try to outline as many of these changes as we can, but bear in mind that our constant quest for better design had us implement incremental improvements with each and every mobile stage we built: we might forget to tell you about some of them! One thing is for sure, their superior technology and unique innovations ensure they will remain unequalled for quite some time. Enjoy your new 24 20 15 : You can rest assured you have purchased the best mobile stage money can buy in its category !

© Copyright Mega-Stage 2006

Any representation or reproduction, in whole or partial, made without written consent from Mega-Stage is prohibited (Law of March 11, 1957, article 40, subparagraph 1). Such representation or reproduction, by any means, constitutes counterfeiting punished by article 425 et sq. of the Criminal Code.



New Dynastage 24 20 15 Mark II mobile stage shown with optional sound wings outriggers and canopies

Contents

<i>Table of contents</i>	<i>Page 1</i>
<i>Introduction</i>	<i>Page 2</i>
<i>Technical specifications</i>	<i>Page 3</i>
<i>Rigging Plan</i>	<i>Page 4</i>
<i>Side view</i>	<i>Page 5</i>
<i>Front view</i>	<i>Page 6</i>
<i>Stage floor</i>	<i>Page 7</i>
<i>Trailer</i>	<i>Page 9</i>
<i>Detailed specifications</i>	<i>Page 10</i>
<i>Contacts</i>	<i>Page 20</i>





Table of contents	Page 1
Introduction	Page 2
Technical specifications	Page 3
Rigging Plan	Page 4
Side view	Page 5
Front view	Page 6
Stage floor	Page 7
Stage floor optional extensions	Page 8
Trailer	Page 9
Detailed specifications	Page 10

A. Trailer

1. Drawbar	Page 10
2. Fifth wheel	Page 11
3. Suspension	Page 11
4. Brakes	Page 11
5. Rims	Page 11
6. Tires	Page 12
7. Transport	Page 12

B. Floor

1. General	Page 13
2. Adjustable legs	Page 13

C. Roof

1. General	Page 13
2. Front of house (FOH) supports	Page 14
3. Side wings	Page 14
4. Hanging points	Page 15
5. Banner supports	Page 15
6. Side banner supports	Page 15
7. Sound wing canopies	Page 16

D. Hydraulic system

1. General	Page 16
2. Engine	Page 16

E. Accessories

1. Stairs	Page 17
2. Stairs Extension	Page 17
3. Balustrades	Page 17
4. Ramp	Page 18

F. Fabrics

1. Back and side wind-walls	Page 18
2. Stage skirt	Page 19
3. Screens	Page 19

Installation

Installation	Page 20
A. Choosing the location	Page 20
B. Leveling	Page 20
C. Stage set-up	Page 21
D. Stage take-down	Page 24
E. Installing the wind-walls	Page 25

Maintenance and safety

Page 26

Troubleshooting

Page 28

Warranty

Page 29



Thank you for selecting our Mega-Stage mobile stage product.

This manual explains the operation and maintenance of the Dynastage Model 24 20 15 mobile stage. All directives in this manual are based on the latest product information available at the time of printing.

Mega-Stage reserves the right to make changes at any time, without prior notice and without any obligation.



Warns you against a strong possibility of extreme bodily damage, or even death, as a result of ignoring these instructions.



Warns you against possible breakage or damage to other equipment as a result of ignoring these instructions.



Provides useful information.

If you encounter any problem or for any question regarding your mobile stage, please contact Stephan Berger at 1 888 359-4001 between 08:00h and 17:00h (US Eastern time and Canada GMT -5h) or consult our website at www.mega-stage.com

Your Mega-Stage mobile stage is designed to provide safe and reliable performance so long as it is used according to the instructions detailed in this manual. Before you start using this mobile stage, make sure you read and understand all of the directives, otherwise you may expose yourself to potential harm or damage the equipment.

Serial number : _____



Trailer

Width	8'-4 1/4" or 2,55 m
Length	33'-8 3/8" or 10,27 m
Height	12'-7 3/4" or 3,85 m
Nominal gross vehicle weight	12 000 lbs or 5 443 kg
Axle(s) capacity	14 000 lbs or 6 350 kg
Weight on hook	2 000 lbs or 907 kg
Cargo space	3'-11 1/2" x 8'-7" x 24'-0" (815 ft ³) 1,21 m x 2,67 m x 7,32 m (23,08 m ³)

Overall dimensions (stage)

Depth	20'-5" (23'-9 3/4" with FOH) 6,22 m (7,26 m with FOH)
Width	26'-2" (33'-10" with PA wings) 7,98 m (10,31 m with PA wings)
Height	19'-4" to 20'-8 1/2" (28'-2" with banners) 5,89 m to 6,31 m (8,58 with banners)

Stage dimensions

Floor dimensions	24'-3/4" x 20'-5" or 7,33 m x 6,22 m
Ground to floor height	3'-9" to 5'-1 1/2" or 1,14 m x 1,56 m
Clearance under trussing	14'-2" or 4,32 m
Clearance under roof	15'-7" or 4,75 m

Other specifications

Floor materials	Non-skid epoxy finish plywood bonded to steel (galvanized steel optional)
Load bearing capacity of the floor	100 lbs per ft ² or 488 kg/m ²
Roof materials	Fiberglass bonded to aluminum structure
Front of house (FOH) supports dimensions	6'-0" or 1,83 m
PA wings dimensions	3' - 9" or 1,14 m
Hanging pipes	Six (6) industry-standard 2" (50,8 mm) nominal diameter
Maximum load bearing : Roof	6 300 lbs* or 2 858 kg
Maximum load bearing : FOH supports	250 lbs* or 113,4 kg
Maximum load bearing : Inside supports	500 lbs (optional)* or 226,8 kg
Maximum load bearing : PA wings	500 lbs * or 226,8 kg
Maximum load bearing : Center truss	2 400 lbs * or 1 089 kg
Maximum load bearing : End truss	500 lbs* or 226,8 kg
Wind resistance	60 mph / 100 km/h with wind wall up 70 mph / 130 km/h without wind wall
Wind lift resistance	20 lbs per ft ² or 98 kg/m ²
Motor	6.5 HP fuel powered Honda GX200
Install time	35 minutes
Transport	Pick-up truck
Wind screen (sides and back)	Black 14 oz. Vinagard with Keder-type aluminum railing
Wind screen openings (doors)	One 6' x 8' (1,83 m x 2,44 m) and two 5' x 8' (1,52 m x 2,44 m)
Wind screen openings (wind flaps)	Three 6' x 3' (1,83 m x 0,91 m) and two 5' x 3' (1,52 m x 0,91 m)
Stage skirt	Black Novathene TG
Stairs	44" (1,12 m) wide with handrails

* Refer to rigging plan

All dimensions and specifications are subject to change without prior notice.

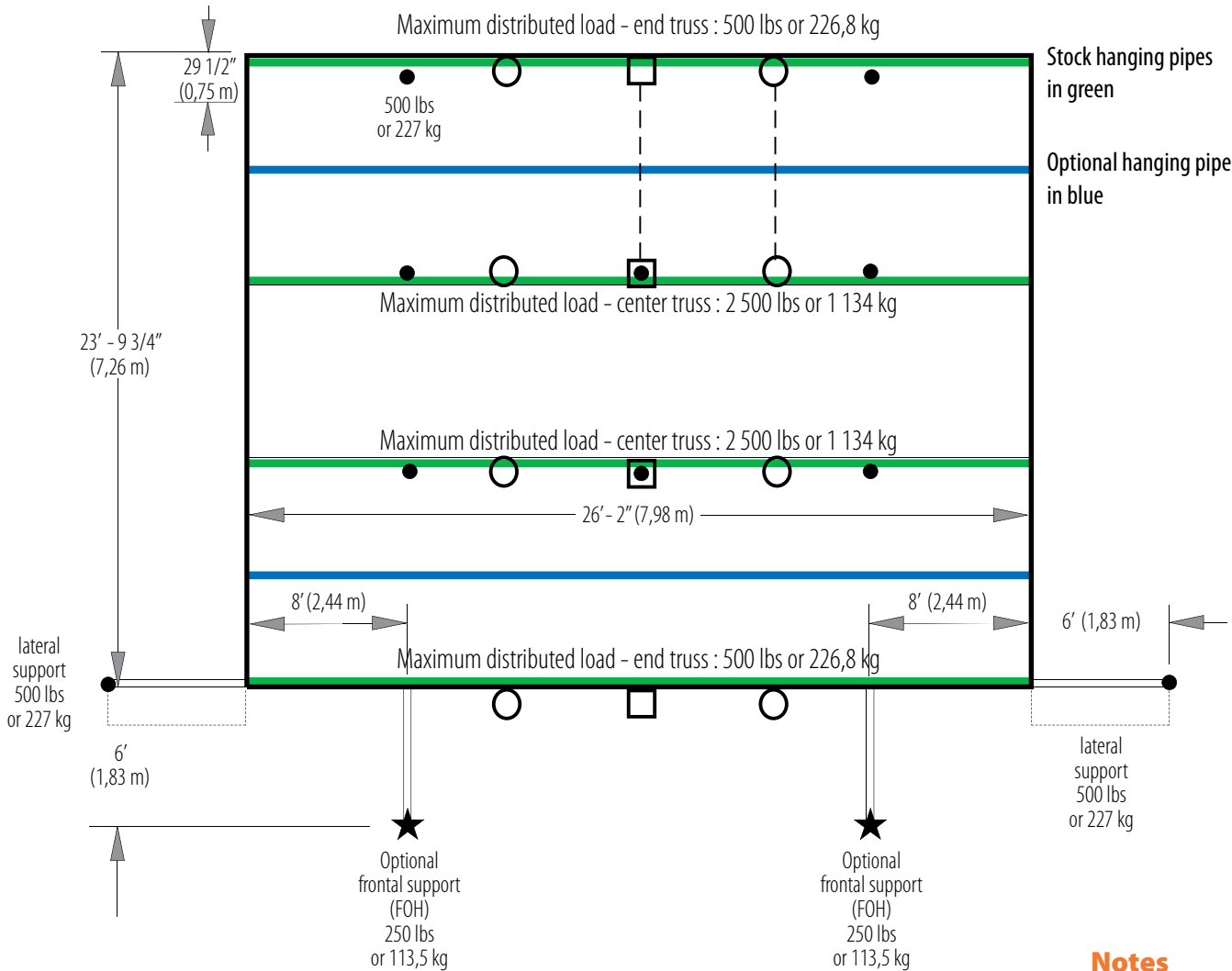

Maximum load

6 300 lbs or 2 858 kg

Distribution

- A: 1 250 lbs or 567 kg
- B: 250 lbs or 113,5 kg
- C: 1 000 lbs or 454 kg
- D: 250 lbs or 113,5 kg
- E: 750 lbs or 340 kg
- F: 250 lbs or 113,5 kg

Center truss

1 of the 3 following setups

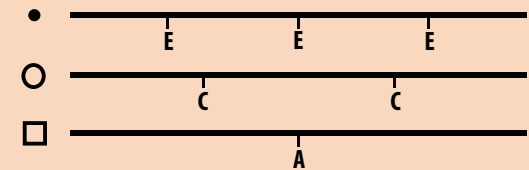

End truss

1 of the 3 following setups

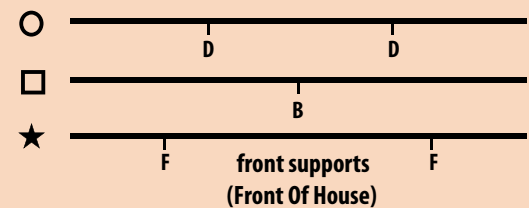

Notes

- * Inside supports replace corresponding rigging points
- ** PA wings may be used with any rigging combination
- *** Lifting capacity 6 300 lbs or 2 858 kg

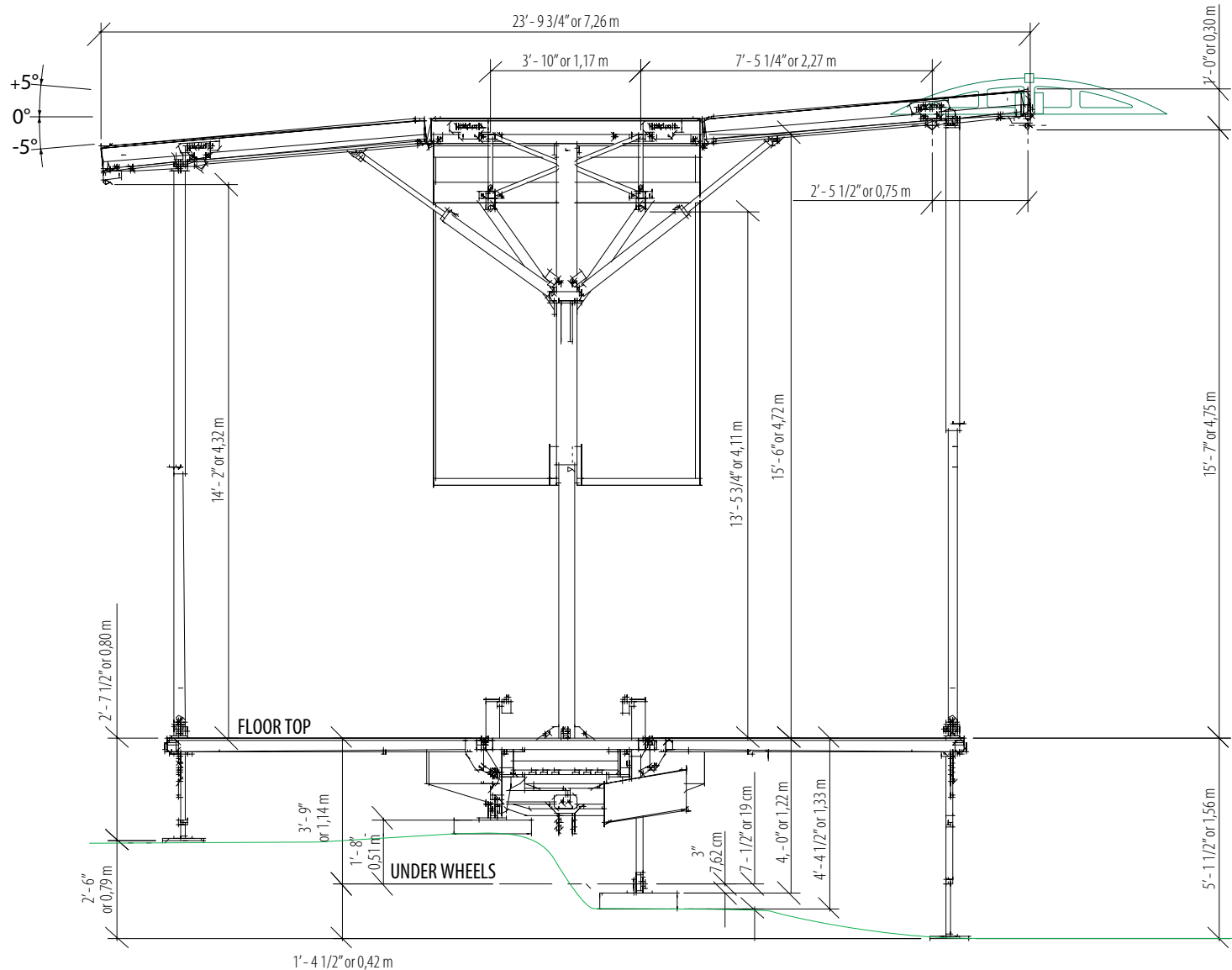

CROSS-SECTION

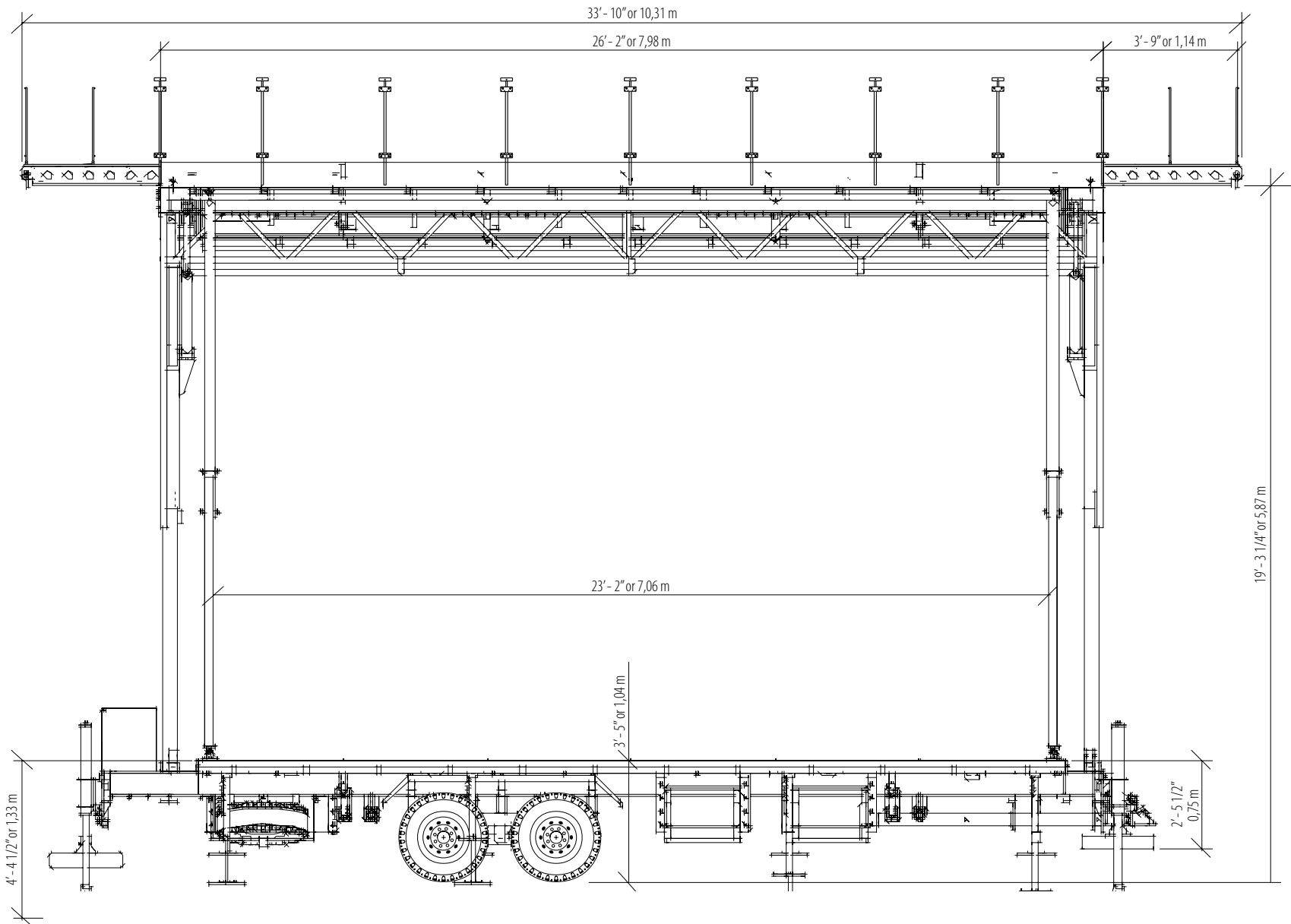

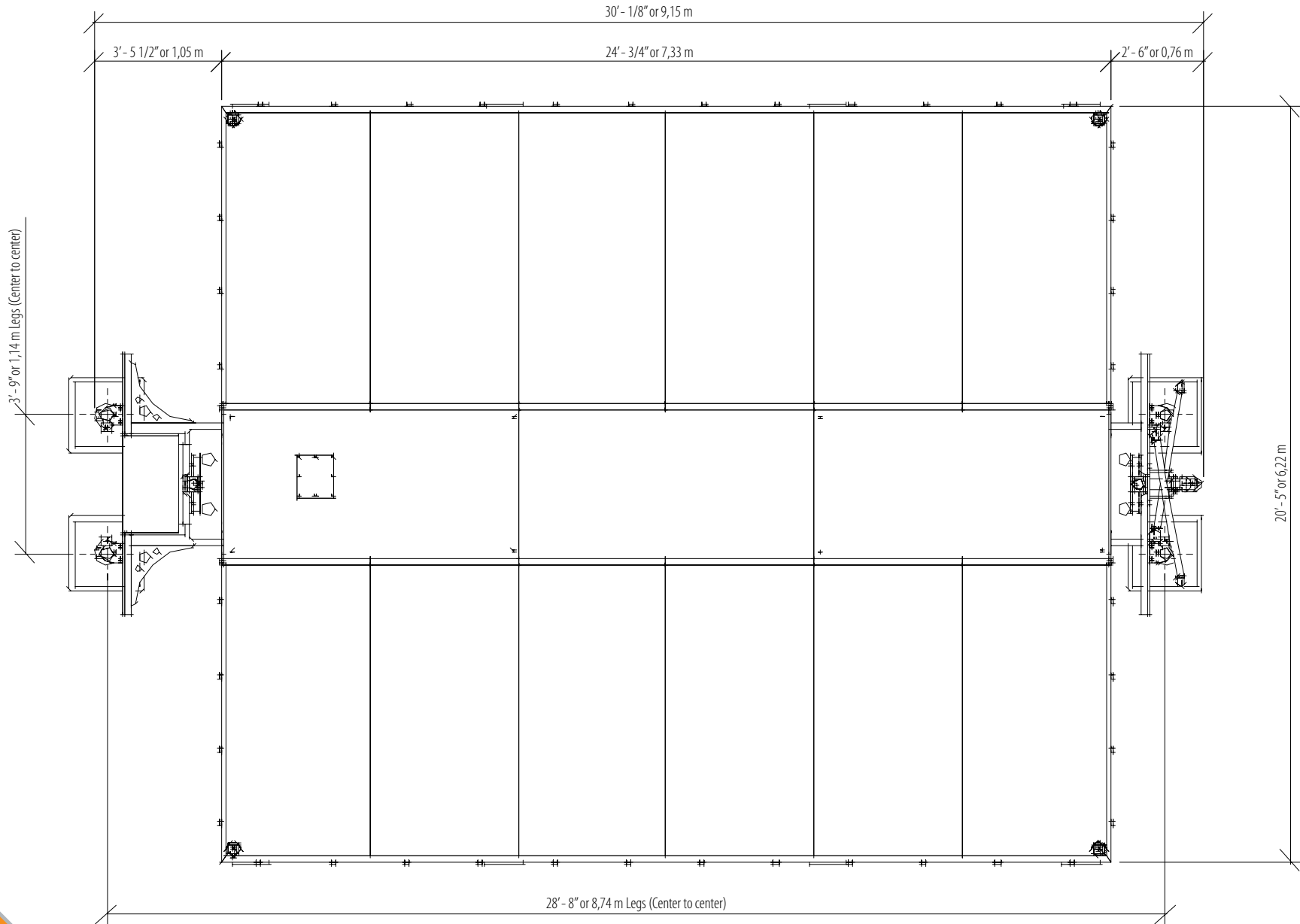

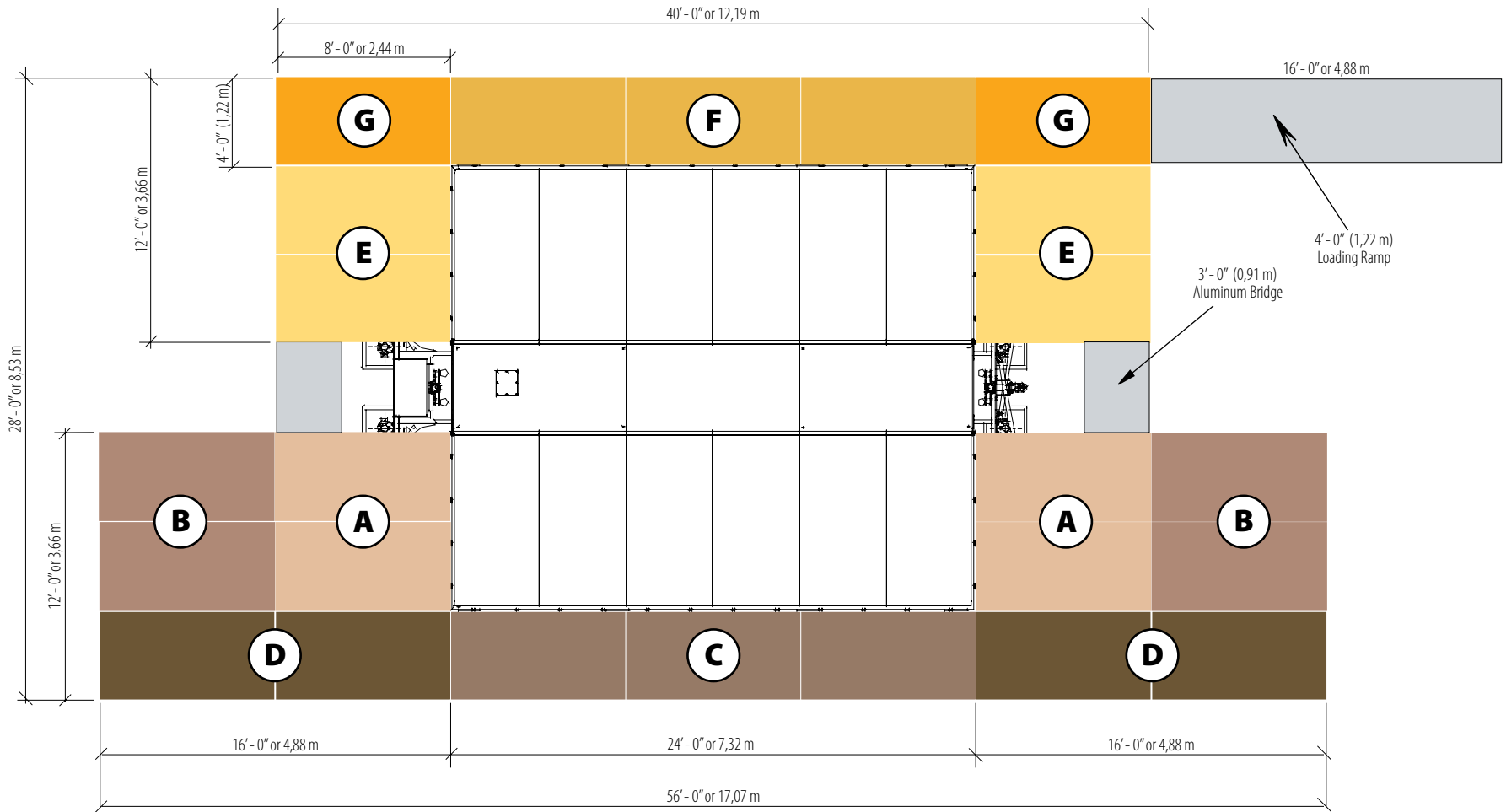

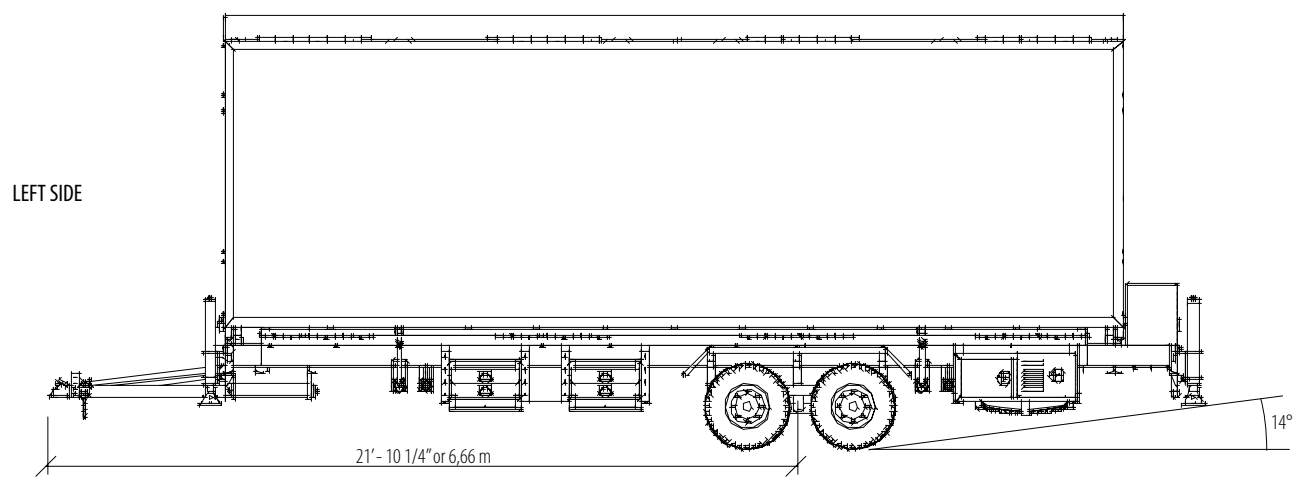
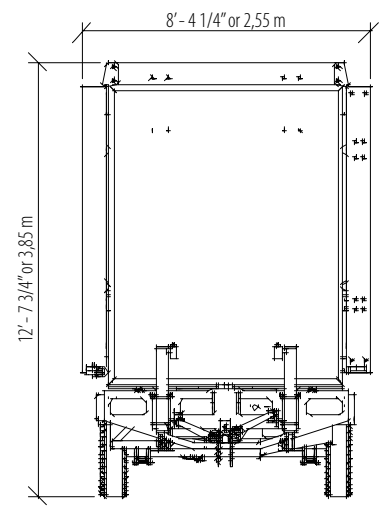
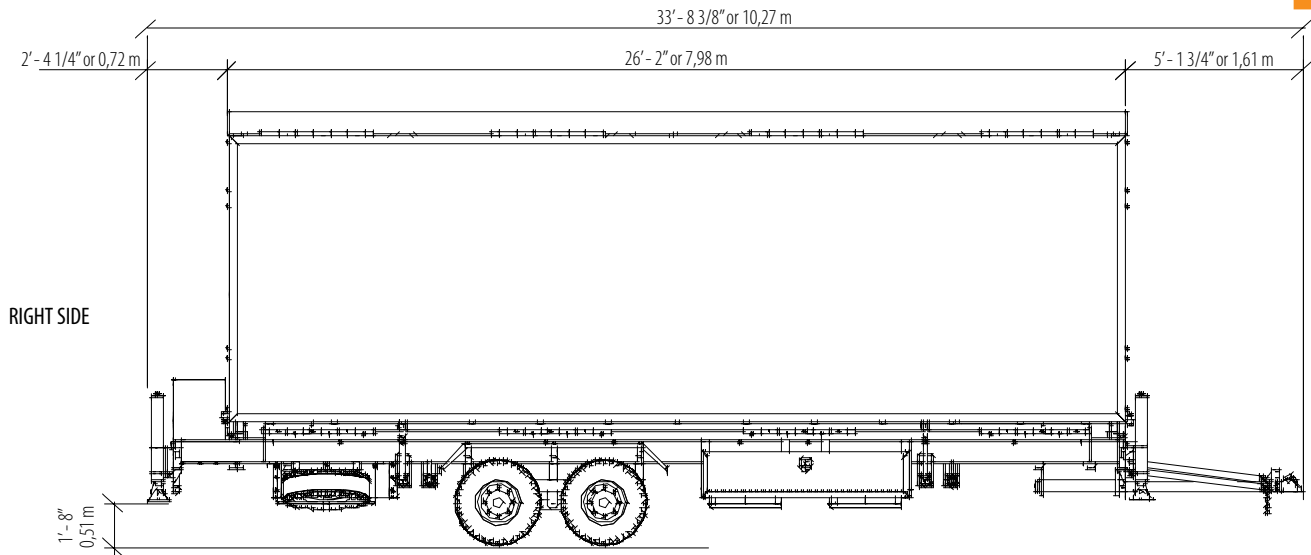



A. Trailer

2 axles

Width:	8'-4 1/4" or 2,55 m
Length:	33'-8 3/8" or 10,27 m
Height:	12'-7 3/4" or 3,85 m
Weight:	12 000 lbs or 5 443 kg
Axle capacity:	14 000 lbs or 6350 kg
Weight on tow ball:	2 000 lbs or 907 kg

1. Drawbar

Product: Standard tow ball and socket coupling body arrangement

Description: Bolted galvanized steel drawbar
 Ball : 2 5/16" (5,87 cm) diameter only
 Maximum Capacity : 14 000 lbs or 6350 kg



Nuts and bolts securing the drawbar must be 5/8" (15,9 mm) Grade 8 or better, and be correctly tightened between 109 and 188 lbf-ft. (148-256 N.m).

The drawbar is a telescoping system with safety chains, fully retractable under the stage during performances.

The drawbar handles a 2 000 lbs (907 kg) vertical load.



See the Safety and maintenance rules section





A. Trailer

2. Optional fifth wheel

Description: Steel fifth wheel adapts to all tractor trucks.

The fifth wheel is removable. If you wish to take it off, simply put blocks under the truck's fifth wheel, remove the pins connecting the fifth wheel and the stage (3), undo the air hoses and leave with the truck. It can be laid to rest somewhere on the site, lower its levers and then take the truck away.

3. Suspension

Product: Dexter Axle leaf suspension
 Description: Multi-leaf slipper type spring suspension
 shot peened to resist fatigue and increase trouble free service life
 14 000 lbs (6 350 kg) capacity per axle



See the Safety and maintenance rules section



4. Brakes

Description: Duty req. brakes with emergency break away system

5. Rims

Description: 16" (406 mm) eight bolts white steel rims
 (Optional mag wheels)





A. Trailer

6. Tires

Product: Goodyear 235 / 85 R 16
 Description: 30.5" (775mm) Diameter
 3000 lbs Capacity at 80 psi per tire (1 360 kg at 3,83 kpa)



See the Safety and maintenance rules section

7. Transport

The trailer can be towed by pick-up trucks equipped with a 2 5/16" (5,87 cm) diameter towing ball (A) or fifthwheel attachment (B). Any standard tractor truck can be used with the optional fifth-wheel.



Always make sure to secure the trailer to the truck with the safety chains.
 The drawbar has a 14 000 lbs (6 350 kg) capacity.

Make sure the drawbar or fifth wheel is properly secured to the trailer.



A



B

Fifth wheel closed

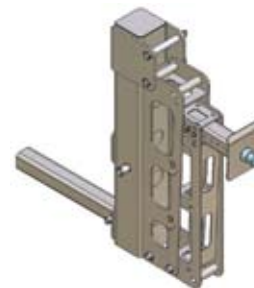

Fifth wheel in open position





B. Floor

1. General

The floor is made of black non-skid epoxy finished 7 plies 3/4" (17,5 mm) BC Fir plywood bonded to a steel structure (galvanized steel an option). The load bearing capacity of the floor is 100 lbs per square foot (5 kpa).

2. Adjustable floor supports

The floor legs are made of round steel tubing with a height adjustment jack. They allow for floor height adjustments from 3'-9" to 5'-1" (1,14 to 1,55m) in 1" (25,4 mm) increments. Ending the steel tubes, there is a reinforced polyamid base with a 4 1/4" (108mm) diameter on a ball joint mount. A micro-levelling screw allows additional ajustements up to 4 1/2" (114 mm). Each leg can support 3300 lbs (1 497 kg).

C. Roof

1. General

The roofing structure is 1/8" thick (3 mm) fiberglass bonded to steel. Watertightness between roof sections is ensured by a reinforced .045 mils (1,15 mm) EPDM membrane to resist tearing. The membrane resists to temperatures of 5° to 482° F (-15° C to 250° C). The corner supports can be set to one of three different positions allowing slopes of 5°, 0° or -5°. Toughlite™ flooring material , stairs and guardrails are offered as options to use the roof as a terrace

Total load bearing capacity: 6 300 lbs or 2 858 kg — See rigging plan on page 4 for details.



C. Roof

2. Front of house (FOH) supports (optional)

Material: Aluminum
 Length: 6'- 0" (1,83 m)
 Capacity: 250 lbs (113,4 kg) each

FOH supports are used to rig the front lighting truss. They are equipped with rigging points accordingly.



When the FOH supports are loaded, it is forbidden to use the front end truss.

3. Side PA wings

Material: aluminum
 Length: 3'- 9" (1,14 m)
 Capacity: 500 lbs (226,8 kg) with corner supports in position.

These outriggers are used to hang loudspeaker arrays. They slide neatly in and out of the roof as needed, and a locking mechanism secures them in position. An optional canopy is offered to protect the arrays (See page 16).





C. Roof

4. Hanging points

Description: Six (6) included steel hanging points for the rigging of chain falls or with pipe hooks.
 Capacity: 500 lbs (226,8 kg)

Their unique design allows the user to replace them as needed, without any welding. They are clearly rated for safety.



5. Top banner supports (optional)

Material: aluminum

The top banner supports accommodate advertising panels up to 4'-0" (1,22 m) high by 32'-0" (9,75 m) or less. Panels may be coroplast or fabric. When purchasing side banner supports (item 6), additional supports are provided allowing to extend the top banner from its standard 26' 2" (7,98 m) to a total of 33'-10" (10,31 m).



6. Side banner supports (optional)

Material: aluminum
 Length: 6'-0" (1,83 m)

Side banner supports (one on each side of the stage) are designed to hang screens in front of the loudspeakers. Depth is adjustable to fit all types of speaker cabinets.



C. Roof

7. Sound wing canopies (optional)

Material: Aluminum covered with novathene
 Dimensions: 6'-0" x 4'-0" (1,83 m x 1,22 m)

Stylish canopies adapt perfectly to the sound wing outriggers



D. Hydraulic system

1. General

Stage set-up is accomplished with the use of a high quality hydraulic system. A fuel-powered engine activates an hydraulic pump that moves fluids in the system with a pressure of 2 000 psi (138 Bar). In turn, this process pushes cylinders, setting the various mechanisms in motion, as determined by the control levers in the back of the trailer (See picture). An emergency «kill switch» or «panic button» is also provided.



2. Motor

Product: Honda Gx200 6.5 HP

For operating instructions, maintenance schedules, technical data and safety rules of the Honda motor, please refer to the owner's manual supplied with the stage.



For safety reasons, we strongly recommend to empty the gas tank when moving the stage from one location to another. Check local laws and regulations.





E. Accessories

1. Stairs

Material: aluminum
 Dimensions: 44" (1,12 m) wide
 3'-6" (1,07 m) minimum height
 8" (203 mm) steps
 44" (1,12 m) guardrail height

The stairs are adjustable in height, using telescoping legs at the base of the stairs, raising the unit up to 4'-3" (1,30 m). Two guardrails are supplied with the stairs. Stairs comply with all current standards set by building and safety codes such as step rise and guardrail heights, railing posts spacing, etc. The stairs can be set anywhere on the perimeter of the stage.



2. Stairs extension (optional)

Material: aluminum
 Dimensions: 44" (1,12 m) wide
 8" (203 mm) steps
 16" (0,41 m) additional height provided

Stair extensions (not illustrated) adapt perfectly. They are used when the stage is raised above normal levels and the stairs can't reach anymore.

3. Balustrades (optional)

Material: aluminum
 Dimensions: 7'-10" (2,39 m) wide and 3'-0" (0,91 m) minimum height
 3'-10" (1,17 m) high

Balustrades can be attached anywhere on the edge of the stage and extensions decks. Balustrades are available in two types: regular (comply with all North American safety codes and regulations) and CE marking standards.



E. Accessories

4. Ramps (optional)

Material: Non skid epoxy finished plywood and aluminum, or Toughlite™
 Dimensions: 4'-0" (1,22 m) x 16'-0" (4,88 m) or 24'-0" (7,31m)



Just like the stairs, ramps are designed to mount anywhere around the floor perimeter. They can serve as loading ramps or assist handicapped people. The surface of the ramp is the same as the stage floor, 3/4" (17,5 mm) plywood with a black non-slip finish. 36" (0,91 m) guardrails are supplied with the ramps.

F. Wind-walls

1. Backdrop and wind-walls (optional)

Material:	16 oz. black VinaGARD®	Mega-Open™
Characteristics:	polyvinyl chloride double coated polyester fibre reinforcement flame retardant (NFPA 701 & ULC S-109) UV resistant	Flame retardant and UV resistant open-mesh fabric (NFPA 701 & ULC S-109) reinforced with polyester fibre

Optional wind-walls tightly cover the back and sides of the stage, extending in front of the columns. They attach with awning rod inserts sliding into Keder type rails on the roof structure. They are also secured to the floor by means of aluminum tubing held by ratchet tie-downs for a perfect fit. The backdrop is equipped with a door in its center and three wind traps. Side screens also have a door.



We strongly advise against using the stage during violent windstorms and urge you to lower the roof instead. We consider that winds in excess of 50 mph (80 km/h) pose a serious threat, as they can tear the fabric which, in turn, can cause serious to fatal injuries. When faced with truly excessive winds (over 60 mph or 100 km/h) and lacking the time to lower the roof, we advise you to slash the fabric instead and take cover. We recommend that the operators keep two utility knives in the drawer above the hydraulic controls at all times for such emergencies.



F. Wind-walls

2. Stage skirt

Material: 16 oz. black vinyl

The purpose of skirting is to hide the underside of the stage from the audience. It either snaps onto the stage or attaches through the use of hooks and eyelets. Be careful as you take the skirt off the stage after the show, because it's possible to tear the fabric around the snaps.

3. Screens (optional)

Material: Open mesh #100

Dimension: 4'-0" x 44'-0" (1,22 m x 13,41m) and 6'-0" x 20'-6" (1,83 m x 6,25 m)

Screens can serve to hide the PA system but can also provide prominent advertising space above and on each side of the stage. Screens cannot be used without top and/or side banner supports.



Contacts

MEGA-STAGE, Inc.

927 Gaudette street, Industrial Park
Saint-Jean-sur-Richelieu (Québec) J3B 7S7
Canada

Phone: (01) 450-359-4000
Toll free : 1 888 359-4001
Fax: (450) 359-4242
Email: info@mega-stage.com
www.mega-stage.com

MEGASTAGE USA, LLC.

6430 Shirll Street
Las Vegas NV 89118
United States

(01) 702-307-2150
888-714-8444

info@megastageusa.com
www.megastageusa.com